

SIGNATURE
KITCHEN SUITE



Project Catalogue

True to food™



2023/2024 EDITION



Signature Kitchen Suite is focusing on a new generation of modern cooks, highlighting their passion for food and their innovative spirit.

By offering superior quality solutions and the most advanced technology, we provide the possibility to cook at your best and with the utmost flexibility, respecting food in all its forms. We celebrate performance, design and precision, a mix that sincerely and genuinely honours all players in the supply chain: the people who grow the food, those who prepare it and those who are lucky enough to enjoy it.





Respecting food down to its essence is our manifesto.

True to food™

All good food has its own unique history, from when it is grown to our table. The land and the sea plants and animals, the farmer, the pasta maker, the fisherman, the baker: each has their own task and deserves the greatest respect. Signature Kitchen Suite is proud to participate in this valuable journey.

True to food™ is our manifesto, our mantra: a philosophy aimed at rediscovering the value of foods, by virtue of their origin, their respective nutritional characteristics and their potential in the culinary field. Thanks to the combination of design and cutting-edge technology, Signature Kitchen Suite appliances offer superior quality performance to preserve and enhance the organoleptic properties of any food, thus preserving its quality and freshness. The dedicated refrigeration range lies at the heart of our collection: refrigerators, freezers and wine cellars designed to create infinite combinations of cold according to one's needs and which guarantee maximum precision and respect for food.

For example, Integrated French Door refrigerator/freezer is equipped with a convertible drawer that can be set with custom temperatures to meet the most diverse ingredient storage requirements. The freezer works with just 1°C of variation between the set and actual temperatures: this precise control enables extremely fast cold transfer and therefore greater efficiency and perfect food preservation.





Design

The more discreet, the more interesting. Beauty becomes more unique as it slowly reveals itself. Your kitchen is transformed into an artistic laboratory and your spaces stimulate your creativity.

Signature Kitchen Suite offers a broad and modern concept of luxury, based on the exceptional synergy between design and functionality. This combination results in products that represent excellence, appliances that are beautiful to look at and perfect to use, designed to be experienced in a personal way, based on the multiple needs of modern life. Hygienic and resistant materials, neat and discreet aesthetics, suitable for any kitchen, also thanks to the option of using panels with the same finishes and the same material as your own furniture.

For example, the ovens, with handle-less automatic opening and flush installation, perfectly integrate into your kitchen design whilst being functional in use, allowing you to open the door even when your hands are full.

The Wine cellar shelves, in natural beech wood, are solid to the touch, providing stability and also acting as a natural regulator of internal temperature and humidity.





Smart

Intelligent, intuitive, connected. Signature Kitchen Suite appliances are smart from every point of view, ensuring professional performance even in your home kitchen.

When you are smart, you are smart right down to your DNA. This is why our devices show their intelligence in different ways.

The appliances are noiseless, featuring intuitive, interactive and assisted operation, simple to clean and maintain.

WI-FI ready, with the possibility of being connected to wider control systems throughout the home. All their functions can be managed remotely by means of the LG ThinQ app. The Smart Diagnosis™ System allows you to run a diagnostic on the appliance operation by using your mobile device.

The functionalities of the various products are also smart. For example, refrigerator and freezer shelves are equipped with LED lighting that works by True View® induction, i.e. without physical connections: this allows them to be moved from one level to another with flexibility, automatically reactivating the lighting after each repositioning. The Gourmet Chef function of the ovens supports recipe preparation by indicating the most correct cooking steps starting from the raw material and its weight.

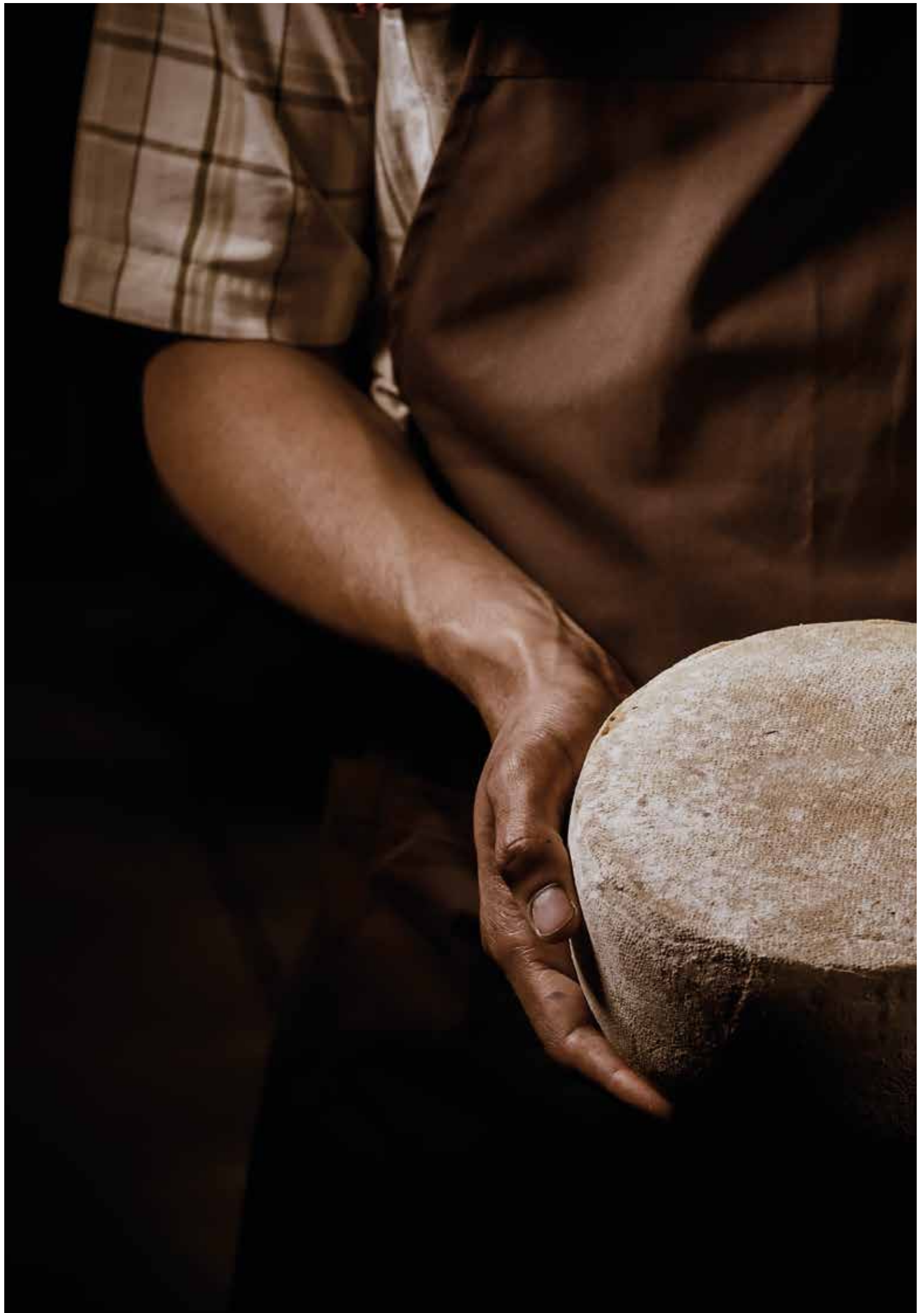

Refrigeration

French Door 36"	16
Column refrigerators	24
Column freezers	38
Undercounter convertible refrigerator	52
Column wine cellar	60
Undercounter wine cellar	74
Built-in combinations with cabinets	82

Cooking

Combi steam oven	94
Combi steam oven with microwave	100
Warming drawer	106
Flex induction hob	112

Washing

Sliding hinge dishwasher	120
--------------------------	-----

Showroom

True to smart floor	128
True to design floor	130
True to food™ floor	132
Food academy	134

True to service

Services and experiences	138
Contact details	142









Refrigeration

Fresh food has finally found a place where it can be cared for. This is the reason why Signature Kitchen Suite provides premium appliances that offer best-in-class storage and freezing capabilities.

The integrated refrigeration range is at the heart of the Signature Kitchen Suite proposal. Panel ready with custom or stainless steel finishes, the column Refrigerator and Freezer, the French Door and the column Wine cellar provide large storage spaces and professional-level performance, even for domestic use. The offer is completed with the Undercounter convertible refrigerator and Undercounter wine cellar, which guarantee all the quality of the Signature Kitchen Suite brand within a compact space.



Refrigeration

French Door 36''

Extremely flexible and spacious, ideal for families and for people who love to share their passion for good food with friends.

A product with a captivating aesthetic that integrates a double-door refrigerator, freezer drawer and central convertible drawer, which can change function as needed.

True Benefits

Convertible drawer

The central drawer can be installed in a custom manner featuring five different temperature modes, which can be selected from the control panel. It can automatically acquire the temperature set in the freezer compartment (from -24°C to -16°C) or, alternatively, meat and fish (-1°C), cold drinks (1°C), gastronomy refrigerator (3°C) and chilled wine (5°C) modes can be selected.



Integrated water and ice dispenser

The cold water dispenser is integrated into the internal side wall, which is activated by pressing a lever directly with the glass. Simple and easy to use, it does not remove useful space from the refrigerator's capacity and integrates perfectly into its design. The dispenser is equipped with a water filter with an average duration of six months. The freezer drawer is equipped with an ice dispenser with a maximum capacity of 2.3 kg. The refrigerator must be connected to the water supply in order for it to work.



Flexible space

Each food item has its own space, thanks to the adjustable shelves and large drawers. The position of the glass shelves is fully adjustable to ensure maximum flexibility, thus creating space even for large volumes such as serving dishes, cake pans, pizza boxes, salad bowls, large fruit or vegetables. The drawers also feature a well-sealed closure to guarantee conservation control and prevent humidity dispersion.



SMART TIP

CONTROL PANEL

It enables to easily manage all settings, from adjusting the temperature of the three compartments to ice production. The open door alarm and the filter change alert are also located here. When the French Door is closed, the display automatically switches off in order to save energy.

SKSFD3614P

Integrated French Door refrigerator/freezer 36"

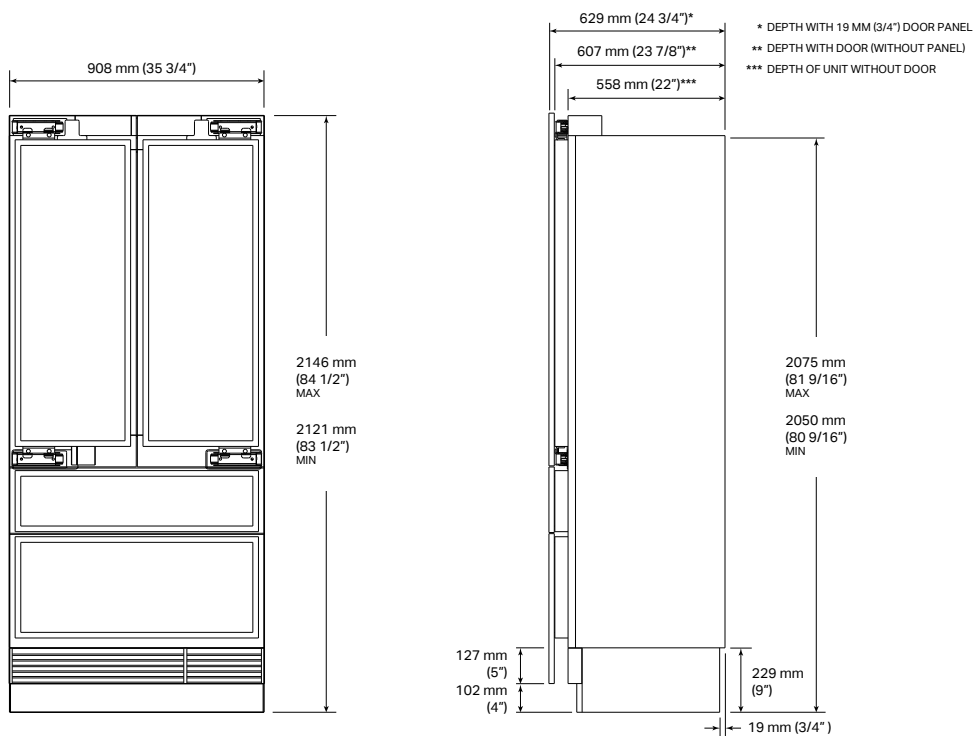

FRONT VIEW

SIDE VIEW

SKSFD3614P

Model	EAN: 8806091454928
Door type	Panel ready
Hinges	Plat
Internal finish	Stainless steel
Energy Label	
Energy efficiency class	F
Net total capacity	545 L
Net refrigerator capacity	383 L
Net freezer capacity	162 L
Maximum sound level	< 39 dbA Max
ENERGY STAR® Qualified	●
Yearly total energy consumption (kWh)	411
Climate class	SN-T
Freezer class	****
General Properties	
No-Frost	●
Inverter Linear compressor	●
2 Independent cooling systems	2 compressors
Wi-Fi enabled for SmartThinQ® control with iOS/Android app	●
Automatic Adaptive Defrost	●
Functions that can be enabled from the control panel	Water Filter, Ice Plus, Ice On/Off, Door Alarm, Wi-Fi, Power On/Off, Demo, Smart Diagnosis™, Temp control
Speed Chill	●
Integrated Water Dispenser	●
Connection to the water supply	●
Water Filter (6 Months)	●
Full-Extension freezer storage drawer	Soft closing
Convertible drawer modes	Freezer, Refrigerator, Meat and Seafood (-1°C), Cold Drinks (1°C), Deli fridge (3°C), Chilled Wine (5°C)
Convertible drawer dividers	2
Storage shelves	2 cantilever adjustable, 1 fixed
Drawer design	2 with telescopic guides and soft closing
True-View® Lighting	●
Aluminium door bins with removable inserts	6
Removable ice bucket capacity	2.3 kg
Digital Controls w/ White LED Display	●
Water Filter Indicator	●
Ice production (24 Hours)	1.6 kg
Ice On / Off	●
Operating temperatures	Refrigerator: 0°C to 6°C / Convertible drawer with 5 temperature modes Freezer drawer: -24°C to -16°C
Installation	
Four Point Front Adjustable with 4 Wheels	●
Attachment method to cabinetry	Top with no visible screws
Front Serviceable	●
Anti-tip Bracket Included	●
Technical Specifications	
Required power supply	230 V, 50 Hz
Power cord length	2200 mm (86.6")
Overall width	908 mm (35 3/4")
Overall height	2121 mm (83 1/2") MIN ~ 2146 mm (84 1/2") MAX
Depth with door panel	629 mm (24 3/4")
Net weight	231 kg
Shipping weight	255 kg
Max packaged product dimensions	2290x968x678 mm (90"x38"x26")
Accessories	
Stainless steel panel / handle / toe kick kit	SKSPK360FS
Side wall cover kit in case of non-flush installation	SKSFK800CS
Joining kit for dual installation	SKSFJ800P
Medium brushed Aluminium Handle – 805 mm	SKSHK310HS
Long brushed Aluminium Handle – 1,218 mm	SKSHK480HS
Replacement water filter	LT1000P-S

SKSFD3614P

Installation Notes

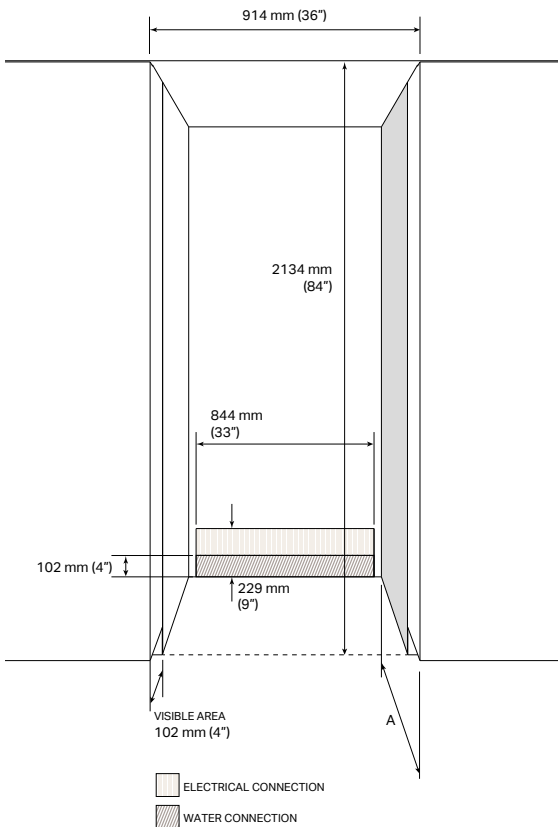

Electrical

230V, 50Hz, 15 or 20° power supply required. It is recommended to set up a three-prong receptacle recessed into the wall and properly earthed, equipped with an individual circuit.

Water connection

A connection to the water mains with a pressure between 1.37 and 8.27 bar (20 and 120 psi) is required. It is recommended to provide a specific cock for closing the circuit, not to be installed directly behind the product for easier accessibility and a pipe (Max Ø 9.5 mm) with a suitable length to reach the front of the refrigerator of approximately 355 mm, with respect to the front of the kitchen doors.

A maximum space of 40 mm from the bottom of the recess is available for the water connection.

Visible area

The indicated area (102 mm) is visible once the refrigerator doors are opened, this area should be finished on both sides.

In case of non-flush installation, we recommend using the **SKSFK800CS** accessory, which consists of side panels that cover any visible side parts of the appliance.

Flush or extended installation

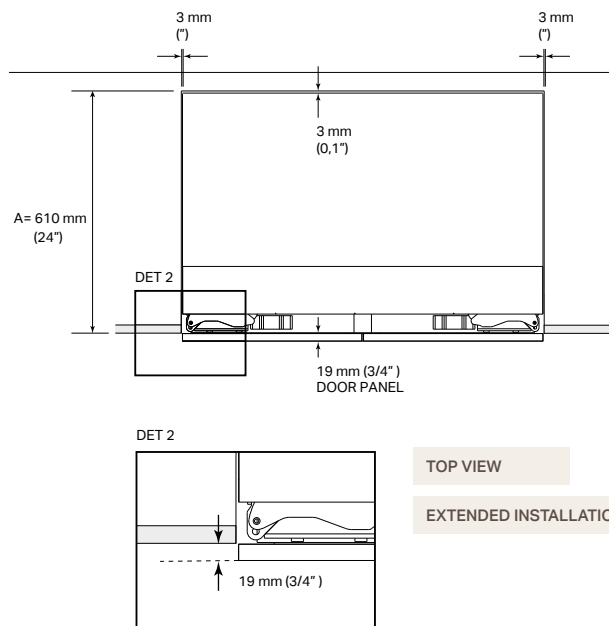
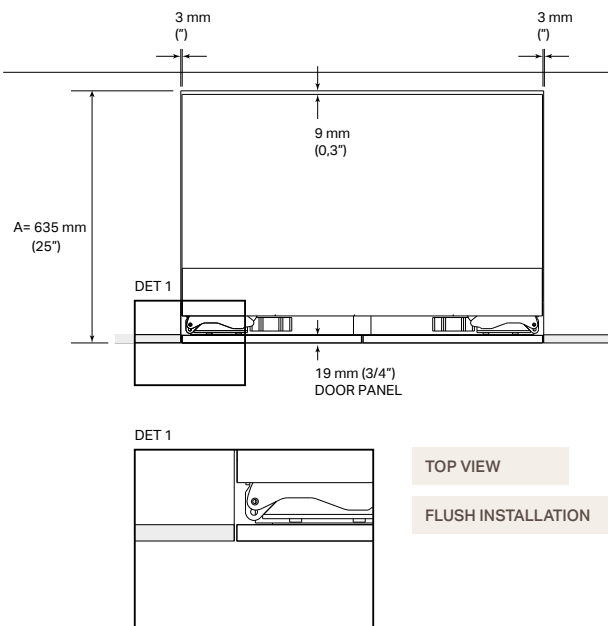

SKSFD3614P

Custom panels

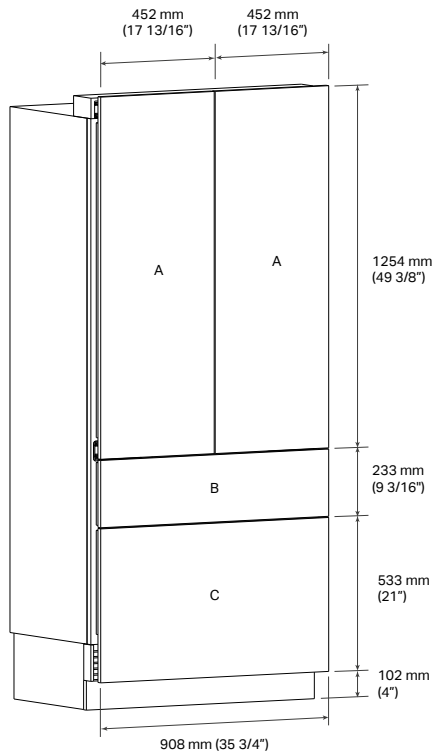

Panel options

SKSPK360FS: Kit with stainless steel panel

The appliance can be panelled with the optional Signature Kitchen Suite stainless steel door kit. The kit includes two fresh refrigerator compartment door panels, one convertible drawer panel (B), one freezer drawer panel (C), one toe kick and four handles.

Custom Panels

The appliance is designed to be customised with panels in line with the aesthetics of kitchen cabinets. For the dimensions of custom panels, refer to the diagram and the indications below:

A - Refrigerator door panels: 1254 mm x 452 mm)

Maximum panel weight permitted: 15 kg

B - Convertible drawer panel: 233 mm x 908 mm)

Maximum panel weight permitted: 10 kg

C - Freezer drawer panel: 533 mm x 908 mm)

Maximum panel weight permitted: 15 kg

Toe kick: 102 mm x 908 mm

A gap between the various panels equal to 4 mm is present.

Design Tips

The Signature Kitchen Suite handles, in brushed aluminium, in the medium or long version, can be purchased separately as an accessory.

SKSHK310HS: Medium handles for custom panels

805 mm (31 11/16") Medium handle – Brushed aluminium

SKSHK480HS: Long handles for custom panels

1219 mm (48") Long handle – Shiny brushed aluminium

Installation Notes

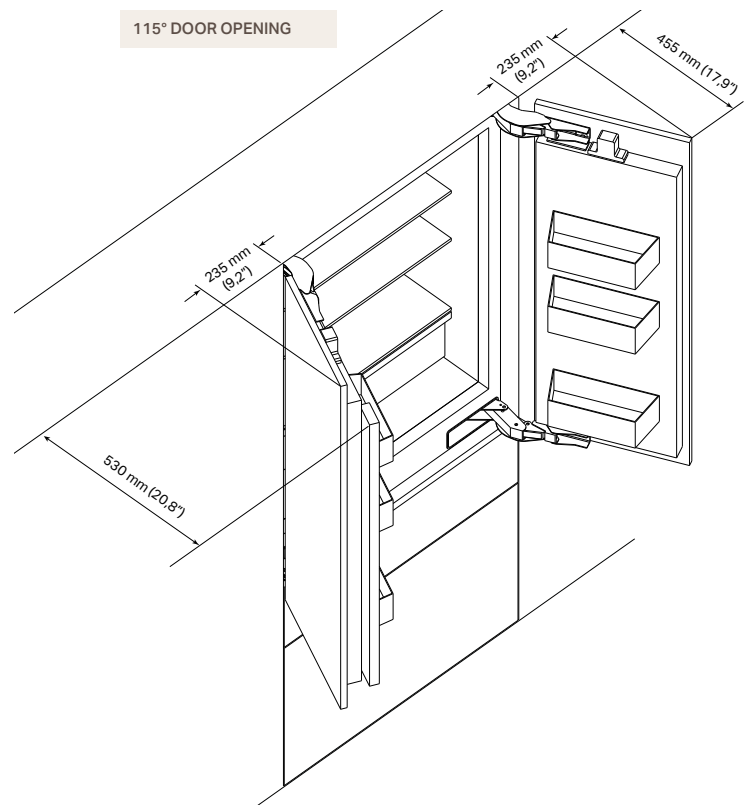
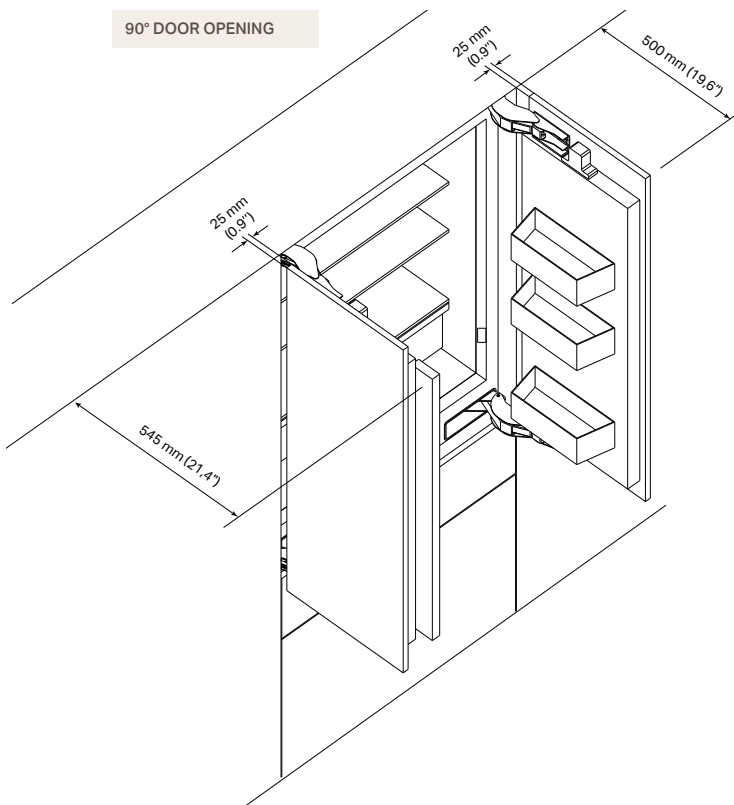

Door clearances with flush installation

The installation must allow for clearances to adjacent walls or cabinets. The factory-set door opening is 115° and can subsequently be adjusted to 90° provided the clearances for opening at 115° are not sufficient.

ATTENTION

The clearance dimensions highlighted in the diagrams DO NOT include the depth of the handles, which must be added to these dimensions in case of a custom extended handle.

When using the Signature Kitchen Suite kit with brushed aluminium handles, the side clearances change as shown:

90° door
Side clearance from 25 mm to 95 mm

115° door
Side clearance from 235 mm to 305 mm

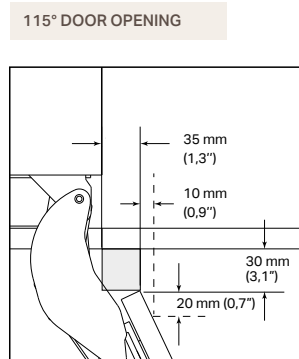
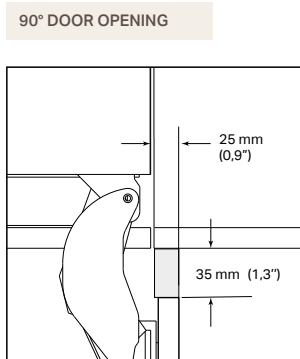

Useful spaces for placing the handle on adjacent cabinets

In case of installation with door opening at 90° for potential placement of a extended handle on the side next to the refrigerator, a handle with a maximum height of 35 mm with respect to the external edge of the panel can be applied for the first 25 mm.

In case of installation with door opening at 115° for potential placement of a extended handle on the side next to the refrigerator, a handle with a maximum height of 30 mm with respect to the external edge of the panel can be applied for the first 35 mm.

A handle can be applied with a 20 mm increment in length for every additional 10 mm increment in distance from the flush cabinet.

True Benefits

True-View™

The intelligent True-View™ system offers a discreet and focused light on each shelf, never directed at the eyes of the person opening the refrigerator thanks to the magnetic induction operation. Each shelf features its own lighting and can be adjusted or removed as needed.



Two independent cooling systems

The French door 36" is equipped with two Linear Inverter compressors, which ensure excellent performance, reliability and silence at the highest levels.

Each compartment (refrigerator, freezer, convertible drawer) is managed electronically by a dedicated evaporator, to ensure maximum precision in terms of temperature management.



Antibacterial filter

The antibacterial filter effectively cleans the air inside the refrigerator by means of exclusive technology.

Thanks to its absorbing power, the activated carbon inside the filter reduces the molecules responsible for bad odorous and the bacteria present inside the refrigerator.



SMART TIP

SMART CONNECTION

The French Door 36" is Wi-Fi ready and can be connected to the LG ThinQ app for remote function management: change the temperatures, check the filter status, set Ice Plus. The app can be used to verify correct operation through Smart Diagnosis™ and receive an alert in the event of a sudden shutdown in order to promptly intervene.



Refrigeration

Column refrigerators

Spacious, flexible and panel ready with stainless steel doors that can be purchased as accessories or with the kitchen finishes.

Column refrigerators are available in 24" or 30" widths, with water dispenser built into the side wall. The interiors are in stainless steel, glass and ABS for the removable inserts.

True Benefits

Bright interiors

The interiors of the refrigerators are entirely coated in stainless steel: they are not only beautiful to look at, but ensure better hygiene and a constant refrigeration temperature in order to keep the ingredients fresher for longer. The high quality and sturdy transparent ABS shelves allow you to see inside of them, ensuring easier identification even of small-sized products.



True-View™

The intelligent True-View™ system offers a discreet and focused light on each shelf, never directed at the eyes of the person opening the refrigerator thanks to the magnetic induction operation. Each shelf features its own lighting and can be adjusted or removed as needed.



Flexible space

Each food item has its own space, thanks to the adjustable shelves and large drawers. The position of the glass shelves is fully adjustable to ensure maximum flexibility, thus creating space even for large volumes such as serving dishes, cake pans, pizza boxes, salad bowls, large fruit or vegetables. The drawers also feature a well-sealed closure to guarantee conservation control and prevent humidity dispersion.



SMART TIP

CONTROL PANEL

It enables to easily manage all settings, from adjusting the temperature to the filter change alert. The door open alarm is also located here. When the column refrigerator is closed, the display automatically switches off in order to save energy.

SKSCR3011P

Integrated column refrigerator 30"

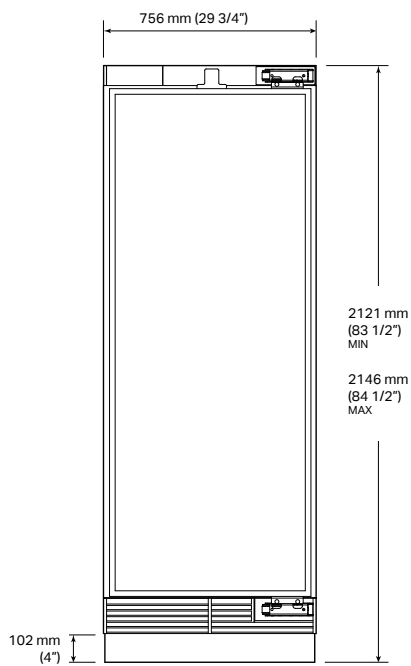

FRONT VIEW

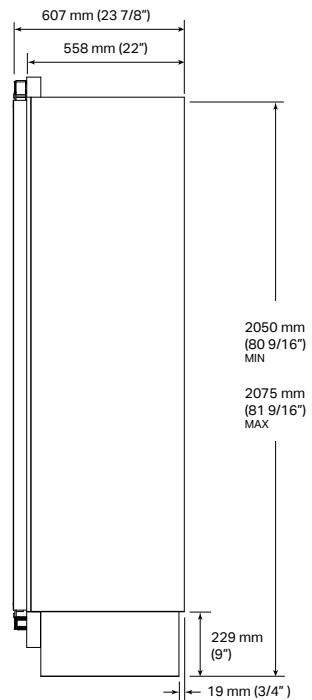

SIDE VIEW

SKSCR3011P

Model	EAN: 8806091454973
Door type	Panel ready
Hinges	Plat
Internal finish	Stainless steel
Energy Label	
Energy efficiency class	E
Net total capacity	516 L
Maximum sound level	< 39 dbA Max
ENERGY STAR® Qualified	●
Yearly total energy consumption (kWh)	125
Climate class	SN-T
General Properties	
No-Frost	●
Inverter Linear compressor	●
Wi-Fi enabled for SmartThinQ® control with iOS/Android app	●
Automatic Adaptive Defrost	●
Functions that can be enabled from the control panel	Water Filter, Door Alarm, Wi-Fi, Power On/Off, Demo, Smart Diagnosis™, Temp control
Speed Chill	●
Integrated Water Dispenser	●
Connection to the water supply	●
Water Filter (6 Months)	●
Storage shelves	3 adjustable and removable
True-View® Lighting	●
Drawer design	3 with telescopic guides and soft closing
Removable door inserts	4
Digital Controls w/ White LED Display	●
Water Filter Indicator	●
Operating temperatures	from 0°C to 6°C
Installation	
Reversible Door	●
Four point front adjustable with 6 wheels	●
Attachment method to cabinetry	Top with no visible screws
Front Serviceable	●
Anti-tip Bracket Included	●
Technical Specifications	
Required power supply	230 V, 50 Hz
Power cord length	2200 mm (86.6")
Overall width	756 mm (29 3/4")
Overall height	2121 mm (83 1/2") MIN ~ 2146 mm (84 1/2") MAX
Overall depth	607 mm (23 7/8")
Net weight	183 kg
Shipping weight	207 kg
Max packaged product dimensions	2290x809x678 mm (90"x31"x26")
Accessories	
Stainless steel panel / handle / toe kick kit	SKSPK305CS
Side wall cover kit in case of non-flush installation	SKSFK800CS
Joining kit for dual installation	SKSFJ800P
Medium brushed Aluminium Handle – 805 mm	SKSHK310HS
Long brushed Aluminium Handle – 1,218 mm	SKSHK480HS
Replacement water filter	LT1000P-S

SKSCR3011P

Installation Notes

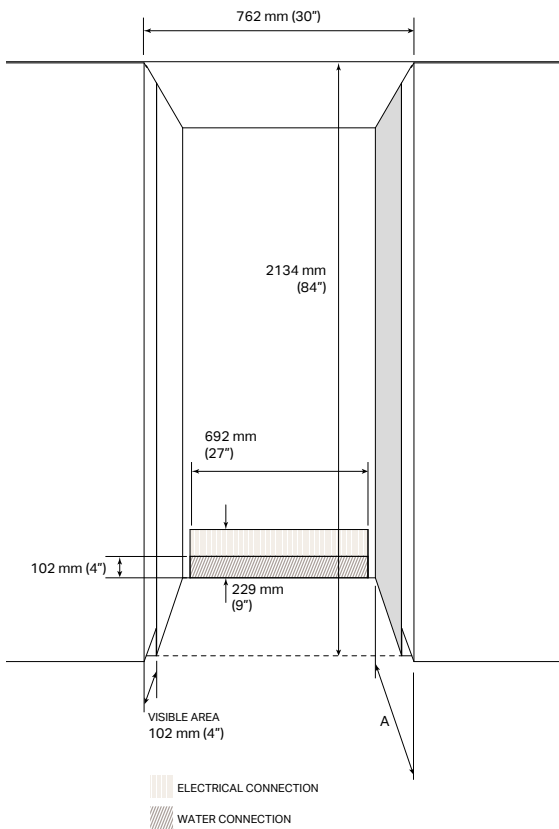

Electrical

230V, 50Hz, 15 or 20° power supply required. It is recommended to set up a three-prong receptacle recessed into the wall and properly earthed, equipped with an individual circuit.

Water connection

A connection to the water mains with a pressure between 1.37 and 8.27 bar (20 and 120 psi) is required.

It is recommended to provide a specific cock for closing the circuit, not to be installed directly behind the product for easier accessibility and a pipe (Max Ø 9.5 mm) with a suitable length to reach the front of the refrigerator of approximately 355 mm, with respect to the front of the kitchen doors.

A maximum space of 40 mm from the bottom of the recess is available for the water connection.

Visible area

The indicated area (102 mm) is visible once the refrigerator doors are opened, this area should be finished on both sides.

In case of non-flush installation, we recommend using the **SKSFK800CS** accessory, which consists of side panels that cover any visible side parts of the appliance.

Flush or extended installation

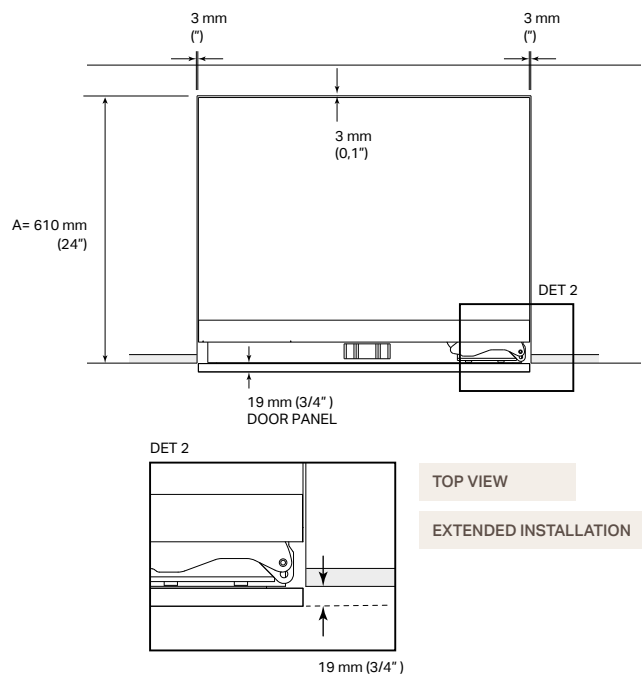
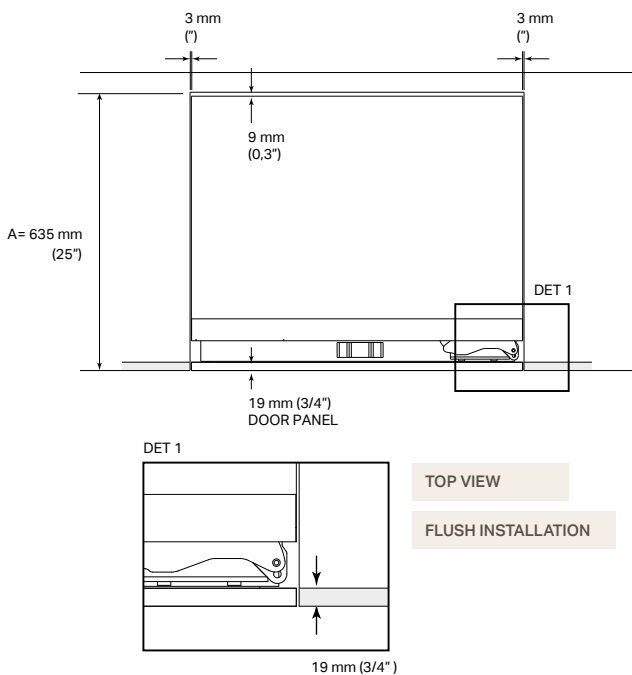

SKSCR3011P

Custom panels

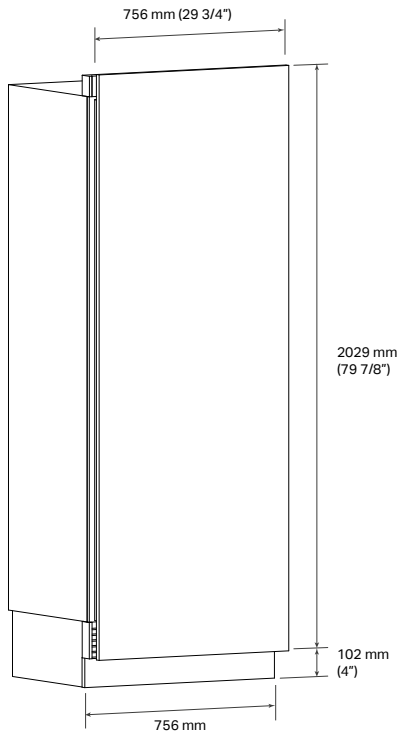

Panel options

SKSPK305CS: Stainless steel panel kit

The appliance can be panelled with the optional Signature Kitchen Suite stainless steel door kit. The kit includes one door panel, one toe kick and one Long handle.

This kit is reversible and can be used in both Right Hand and Left Hand door swing installations.

Custom Panels

The appliance is designed to be customised with panels in line with the kitchen cabinet aesthetics. For the dimensions of custom panels, refer to the diagram and the indications below:

Door panel: 2029 mm x 756 mm

Maximum panel weight permitted: 29 kg

Toe kick: 102 mm x 756 mm

The Signature Kitchen Suite handles, in brushed aluminium, in the medium or long version, can be purchased separately as an accessory.

SKSHK310HS: Medium handles for custom panels

805 mm (31 11/16") Medium handle – Brushed aluminium

SKSHK480HS: Long handles for custom panels

1219 mm (48") Long handle – Shiny brushed aluminium

Custom panel dimensions

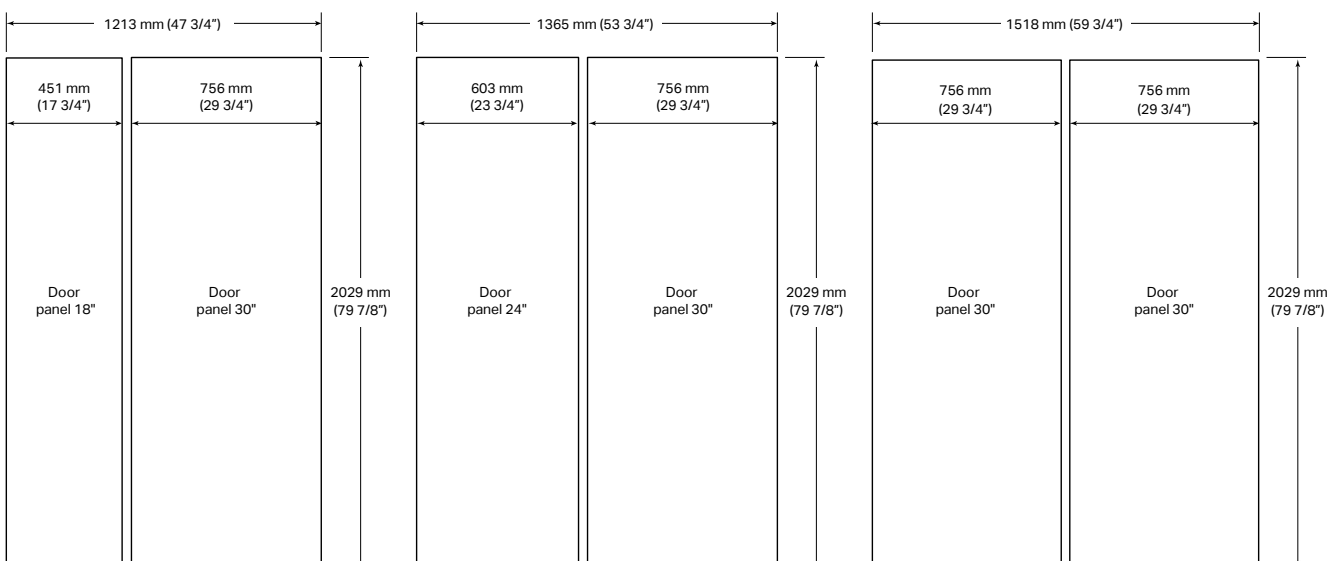

SKSCR3011P

Installation Notes

90° DOOR OPENING

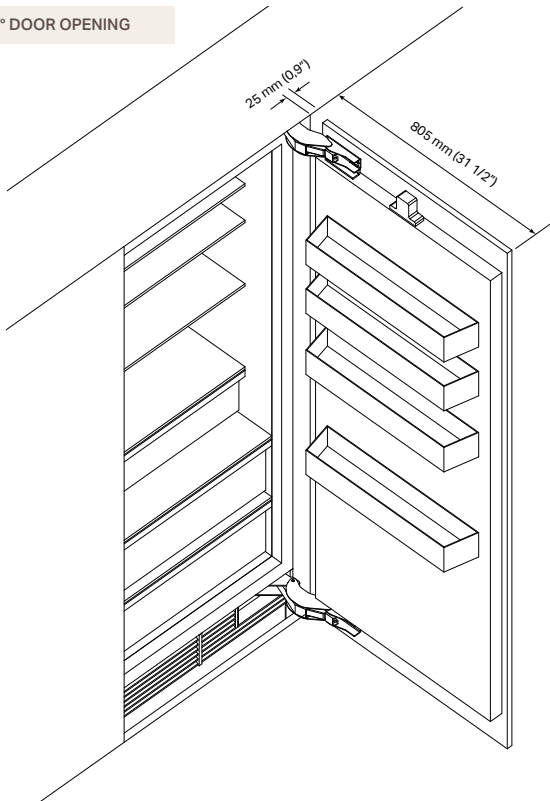

115° DOOR OPENING

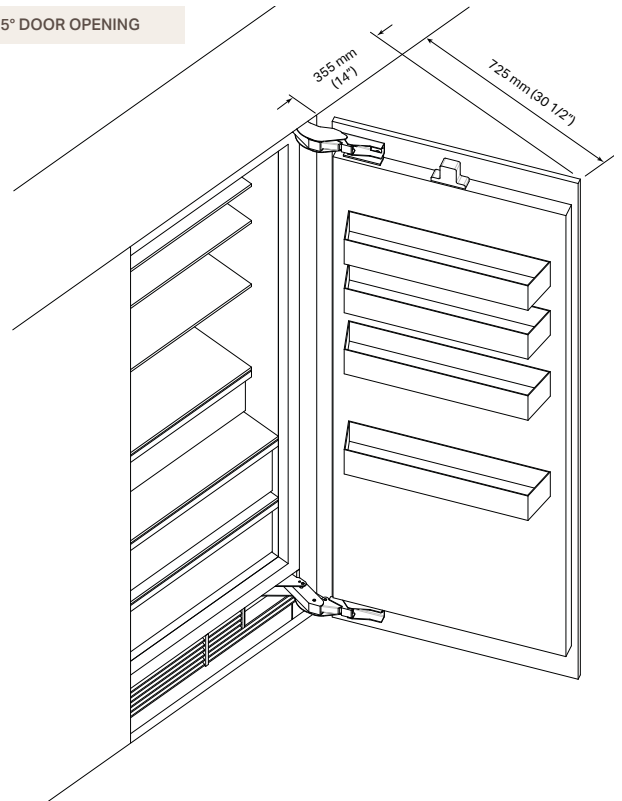

Door clearances with flush installation

The installation must allow for clearances to adjacent walls or cabinets. The factory-set door opening is 115° and can subsequently be adjusted to 90° provided the clearances for opening at 115° are not sufficient.

ATTENTION

The clearance dimensions highlighted in the diagrams DO NOT include the depth of the handles, which must be added to these dimensions in case of a custom extended handle.

When using the Signature Kitchen Suite with brushed aluminium handles, the side clearances change as shown:

90° door
Side clearance from 25 mm to 95 mm

115 door
Side clearance from 355 mm to 425 mm

90° DOOR OPENING

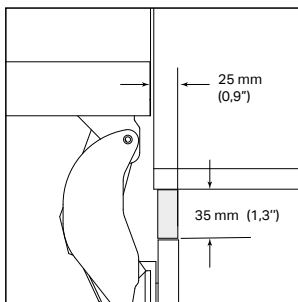

115° DOOR OPENING

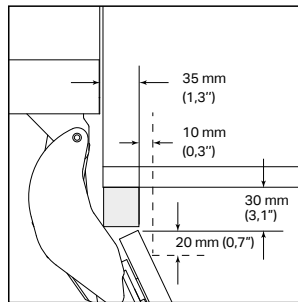

Useful spaces for placing the handle on adjacent cabinets

In case of installation with door opening at 90° for potential placement of an extended handle on the side next to the refrigerator, a handle with a maximum height of 35 mm with respect to the external edge of the panel can be applied for the first 25 mm.

In case of installation with door opening at 115° for potential placement of an extended handle on the side next to the refrigerator, a handle with a maximum height of 30 mm with respect to the external edge of the panel can be applied for the first 35 mm.

A handle can be applied with a 20 mm increment in length for every additional 10 mm increment in distance from the flush cabinet.



SKSCR2411P

Integrated column refrigerator 24"

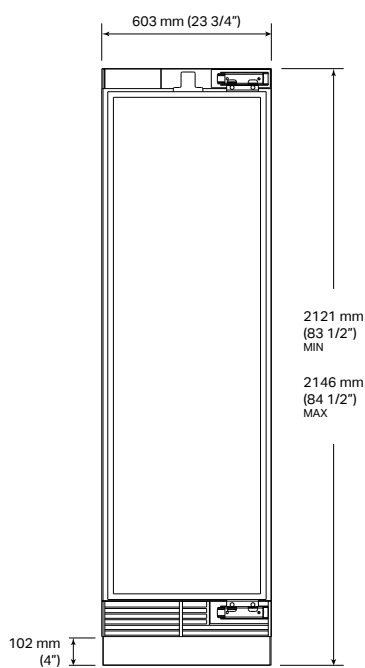

FRONT VIEW

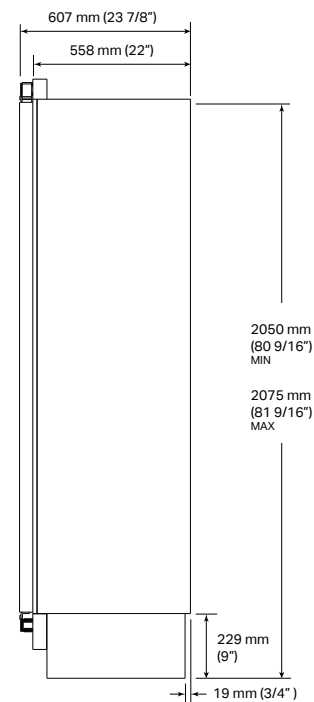

SIDE VIEW

SKSCR2411P

Model	EAN: 8806091454973
Door type	Panel ready
Hinges	Plat
Internal finish	Stainless steel
Energy Label	
Energy efficiency class	E
Net total capacity	397 L
Maximum sound level	< 39 dbA Max
ENERGY STAR® Qualified	●
Yearly total energy consumption (kWh)	123
Climate class	SN-T
General Properties	
No-Frost	●
Inverter Linear compressor	●
Wi-Fi enabled for SmartThinQ® control with iOS/Android app	●
Automatic Adaptive Defrost	●
Functions that can be enabled from the control panel	Water Filter, Door Alarm, Wi-Fi, Power On/Off, Demo, Smart Diagnosis™, Temp control
Speed Chill	●
Integrated Water Dispenser	●
Connection to the water supply	●
Water Filter (6 Months)	●
Storage shelves	3 adjustable and removable
True-View® Lighting	●
Drawer design	3 with telescopic guides and soft closing
Removable door inserts	4
Digital Controls w/ White LED Display	●
Water Filter Indicator	●
Operating temperatures	from 0°C to 6°C
Installation	
Reversible Door	●
Four point front adjustable with 6 wheels	●
Attachment method to cabinetry	Top with no visible screws
Front Serviceable	●
Anti-tip Bracket Included	●
Technical Specifications	
Required power supply	230 V, 50 Hz
Power cord length	2200 mm (86.6")
Overall width	603 mm (23 3/4")
Overall height	2121 mm (83 1/2") MIN ~ 2146 mm (84 1/2") MAX
Overall depth	607 mm (23 7/8")
Net weight	160 kg
Shipping weight	180 kg
Max packaged product dimensions	2290x663x678 mm (90"x25"x26")
Accessories	
Stainless steel panel / handle / toe kick kit	SKSPK245CS
Side wall cover kit in case of non-flush installation	SKSFK800CS
Joining kit for dual installation	SKSFJ800P
Medium brushed Aluminium Handle – 805 mm	SKSHK310HS
Long brushed Aluminium Handle – 1,218 mm	SKSHK480HS
Replacement water filter	LT1000P-S

SKSCR2411P

Installation Notes

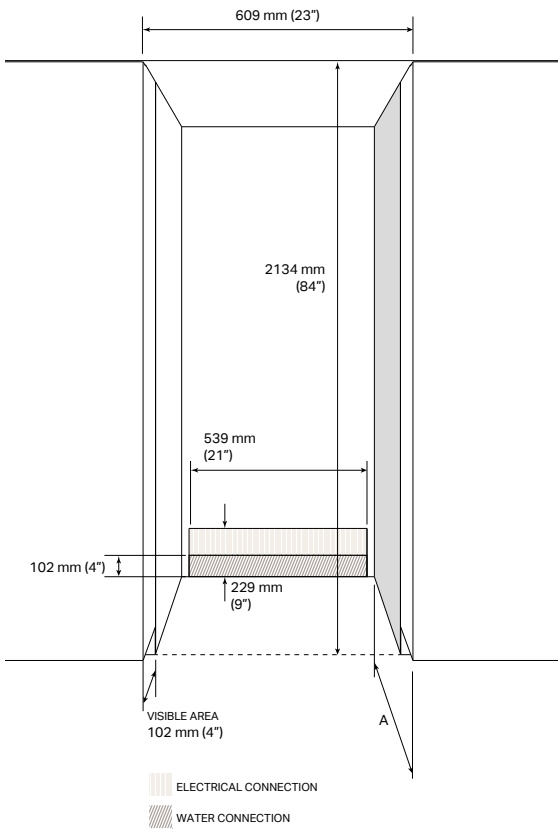

Electrical

230V, 50Hz, 15 or 20° power supply required.

It is recommended to set up a three-prong receptacle recessed into the wall and properly earthed, equipped with an individual circuit.

Water connection

A connection to the water mains with a pressure between 1.37 and 8.27 bar (20 and 120 psi) is required. It is recommended to provide a specific cock for closing the circuit, not to be installed directly behind the product for easier accessibility and a pipe (Max Ø 9.5 mm) with a suitable length to reach the front of the refrigerator of approximately 355 mm, with respect to the front of the kitchen doors. A maximum space of 40 mm from the bottom of the recess is available for the water connection.

Visible area

The indicated area (102 mm) is visible once the refrigerator doors are opened, this area should be finished on both sides.

In case of non-flush installation, we recommend using the **SKSFK800CS** accessory, which consists of side panels that cover any visible side parts of the appliance.

Flush or extended installation

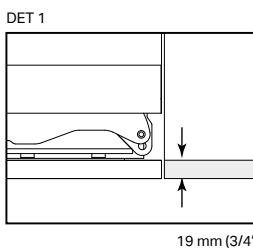
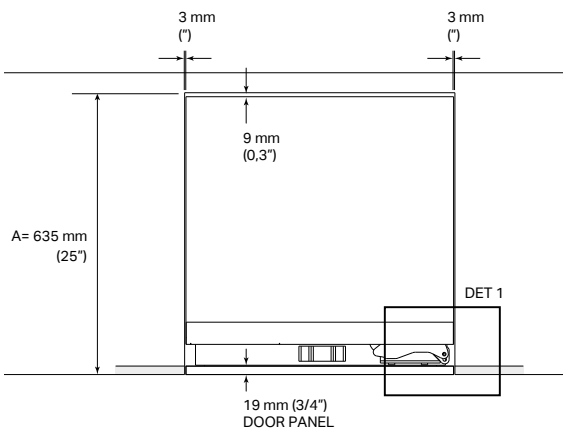

TOP VIEW

FLUSH INSTALLATION

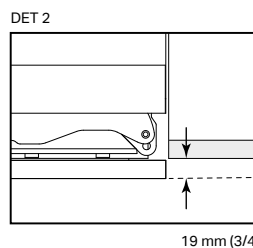
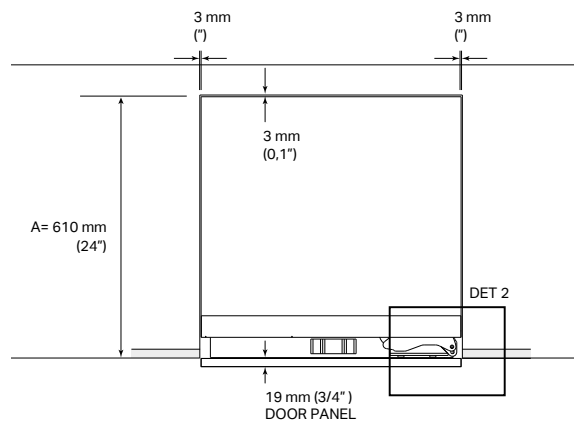

TOP VIEW

EXTENDED INSTALLATION

SKSCR2411P

Custom panels

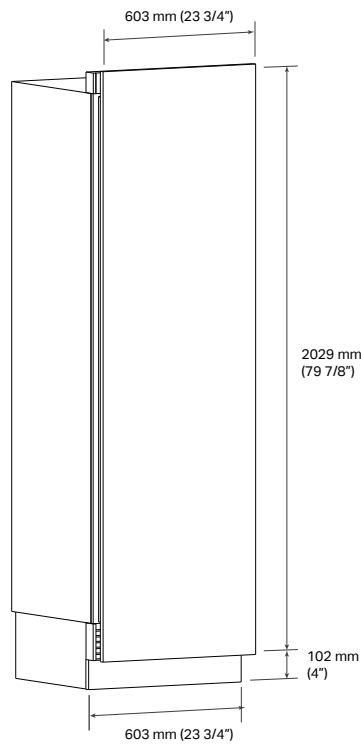

Panel options

SKSPK245CS: Stainless steel panel kit

The appliance can be panelled with the optional Signature Kitchen Suite stainless steel door kit. The kit includes one door panel, one toe kick and one Long handle.

This kit is reversible and can be used in both Right Hand and Left Hand door swing installations.

Custom Panels

The appliance is designed to be customised with panels in line with the kitchen cabinet aesthetics. For the dimensions of custom panels, refer to the diagram and the indications below:

Door panel: 2029 mm x 603 mm

Maximum panel weight permitted: 24 kg

Toe kick: 102 mm x 603 mm

The Signature Kitchen Suite handles, in brushed aluminium, in the medium or long version, can be purchased separately as an accessory.

SKSHK310HS: Medium handles for custom panels

805 mm (31 11/16") Medium handle – Brushed aluminium

SKSHK480HS: Long handles for custom panels

1219 mm (48") Long handle – Shiny brushed aluminium

Custom panel dimensions

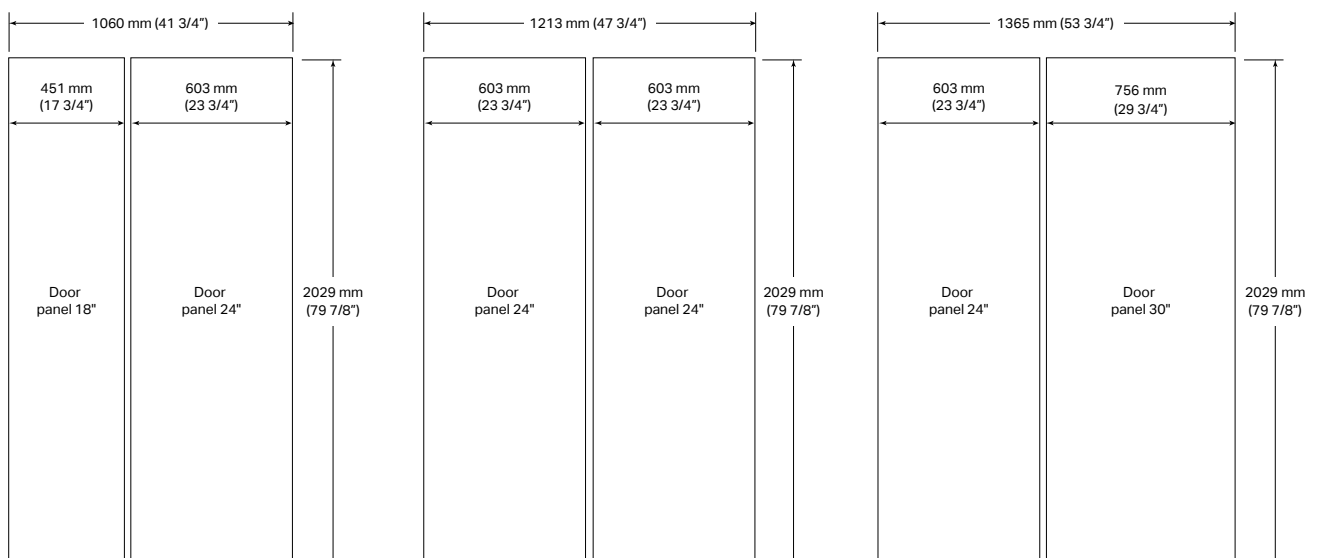

SKSCR2411P

Installation Notes

90° DOOR OPENING

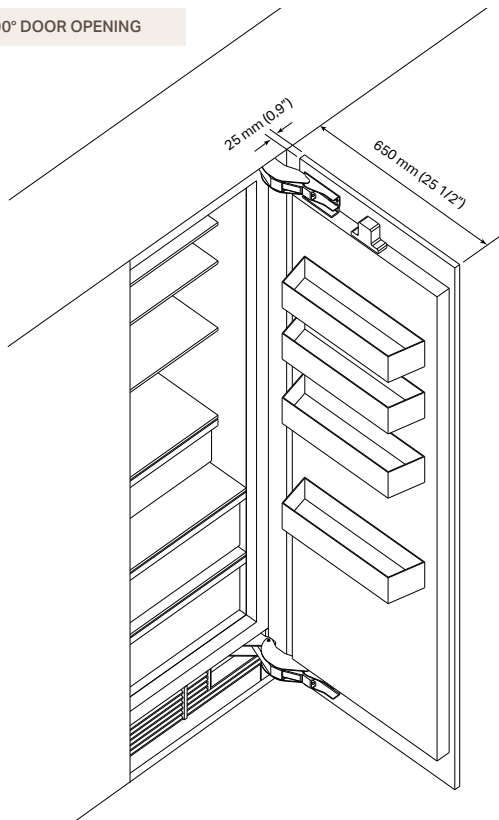

115° DOOR OPENING

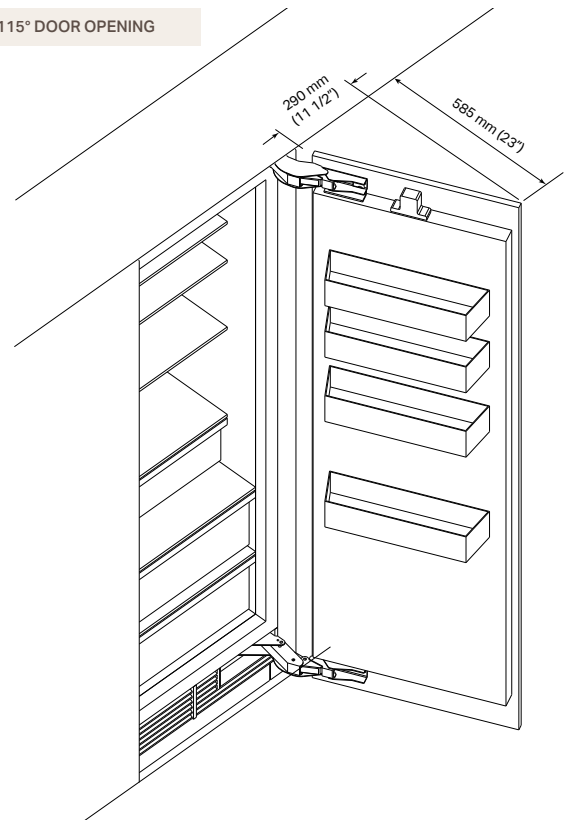

Door clearances with flush installation

The installation must allow for clearances to adjacent walls or cabinets. The factory-set door opening is 115° and can subsequently be adjusted to 90° provided the clearances for opening at 115° are not sufficient.

ATTENTION

The clearance dimensions highlighted in the diagrams DO NOT include the depth of the handles, which must be added to these dimensions in case of a custom extended handle.

When using the Signature Kitchen Suite with brushed aluminium handles, the side clearances change as shown:

90° door
Side clearance from 25 mm to 95 mm

115° door
Side clearance from 290 mm to 360 mm

90° DOOR OPENING

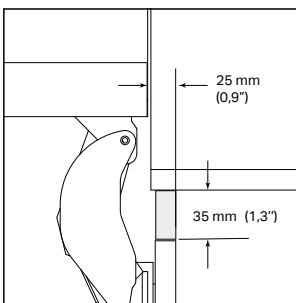

115° DOOR OPENING

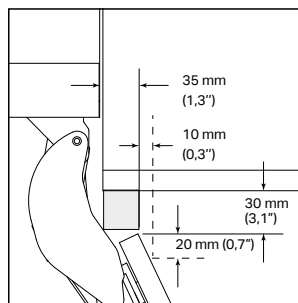

Useful spaces for placing the handle on adjacent cabinets

In case of installation with door opening at 90° for potential placement of an extended handle on the side next to the refrigerator, a handle with a maximum height of 35 mm with respect to the external edge of the panel can be applied for the first 25 mm.

In case of installation with door opening at 115° for potential placement of an extended handle on the side next to the refrigerator, a handle with a maximum height of 30 mm with respect to the external edge of the panel can be applied for the first 35 mm.

A handle can be applied with a 20 mm increment in length for every additional 10 mm increment in distance from the flush cabinet.

True Benefits

Inverter Linear compressor

The Inverter Linear compressor guarantees less wear than traditional compressors, for longer life and optimal performance. It is very quiet since it does not contain mechanical components between the engine and piston, but only 1 point of friction in its operation compared to the traditional 4. It offers an energy savings of 60% with respect to traditional compressors, as it adapts cooling to the actual needs of use.



Antibacterial filter

The antibacterial filter effectively cleans the air inside the refrigerator by means of exclusive technology. Thanks to its absorbing power, the activated carbon inside the filter reduces the molecules responsible for bad odorous and the bacteria present inside the refrigerator.



Flexible space

Each food item has its own space, thanks to the adjustable shelves and large drawers. The position of the glass shelves is fully adjustable to ensure maximum flexibility, thus creating space even for large volumes such as serving dishes, cake pans, pizza boxes, salad bowls, large fruit or vegetables. The drawers also feature a well-sealed closure to guarantee conservation control and prevent humidity dispersion.



SMART TIP

SMART CONNECTION

Column Refrigerators are Wi-Fi ready and can be connected to the LG ThinQ app for remote function management such as changing the temperatures and checking the filter status. The app can be used to verify correct operation through Smart Diagnosis™ and receive an alert in the event of a sudden shutdown in order to promptly intervene.



Refrigeration

Column freezers

Spacious, extremely accurate and panel ready with stainless steel doors that can be purchased as accessories or with the kitchen finishes.

Column freezers are available in 18" or 24" width, with integrated ice dispenser. Paired with Column refrigerator models, they enable to create unique solutions.

True Benefits

Ice dispensers

Equipped with ice dispensers with a maximum capacity of 2.3 kg, Column freezers are perfect for entertaining your guests whenever you desire, thanks to the quality of the water purified by the filter. The freezers must be connected to the water supply in order to function.



Temperature tolerance of only 1°C

The freezers only have 1°C variation between set and actual temperature. This precise temperature control allows for extremely rapid cold transfer and therefore greater overall efficiency, from an energy classification point of view as well as guaranteeing optimal conservation of food.



Flexible space

Each food item has its own space, thanks to the adjustable shelves and large drawers. The position of the glass shelves is fully adjustable to ensure maximum flexibility, thus creating space even for large volumes.

The drawers also feature a well-sealed closure to guarantee conservation control and prevent humidity dispersion.



SMART TIP

CONTROL PANEL

It enables to easily manage all settings, from adjusting the temperature of the three compartments, to ice production. The door open alarm is also located here. When the Column freezer is closed, the display automatically switches off in order to save energy.

SKSCF2411P

Integrated column freezer 24"

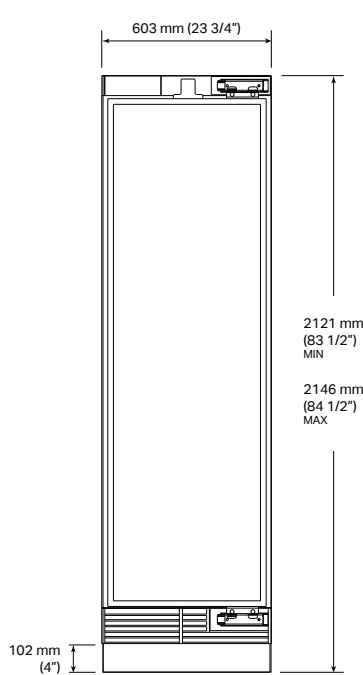

FRONT VIEW

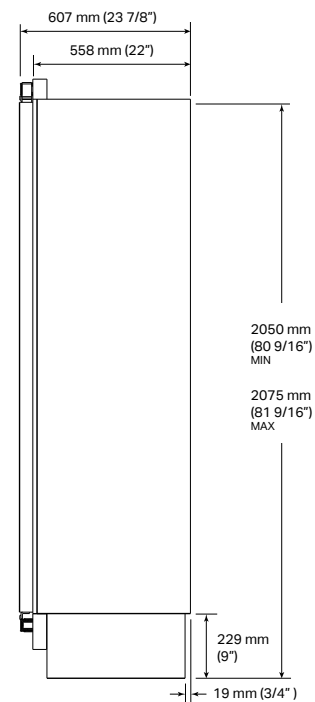

SIDE VIEW

SKSCF2411P

Model	EAN: 8806091454959
Door type	Panel ready
Hinges	Plat
Internal finish	Stainless steel
Energy Label	
Energy efficiency class	F
Net total capacity	396 L
Maximum sound level	< 39 dbA Max
ENERGY STAR® Qualified	●
Yearly total energy consumption (kW/h)	379
Climate class	SN-T
Classification	****
General Properties	
No-Frost	●
Inverter Linear compressor	●
Wi-Fi enabled for SmartThinQ® control with iOS/Android app	●
Automatic Adaptive Defrost	●
Functions that can be enabled from the control panel	Water Filter, Ice Plus, Ice On/Off, Door Alarm, Wi-Fi, Power On/Off, Demo, Smart Diagnosis™, Temp control
Speed Freeze	●
Connection to the water supply	●
Water Filter (6 Months)	●
Storage shelves	3 adjustable and removable
True-View® Lighting	●
Lift and Go™ ice drawer	1 with telescopic guides and soft closing
Lift and Go™ storage drawers	2 with telescopic guides and soft closing
Aluminium door bins with removable inserts	4 cantilever
Removable ice bucket capacity	2.3 kg
Digital Controls w/ White LED Display	●
Water Filter Indicator	●
Ice production (24 Hours)	1.6 kg
Ice On / Off	●
Operating temperatures	from -24°C to -16°C
Installation	
Reversible Door	●
Four point front adjustable with 6 wheels	●
Attachment method to cabinetry	Top with no visible screws
Front Serviceable	●
Anti-tip Bracket Included	●
Unification Kit Included (SKSFJ800P)	●
Technical Specifications	
Required power supply	230 V, 50 Hz
Power cord length	2200 mm (86.6")
Overall width	603 mm (23 3/4")
Overall height	2121 mm (83 1/2") MIN ~ 2146 mm (84 1/2") MAX
Overall depth	607 mm (23 7/8")
Net weight	159 kg
Shipping weight	180 kg
Max packaged product dimensions	2290x663x678 mm (90"x25"x26")
Accessories	
Stainless steel panel / handle / toe kick kit	SKSPK245CS
Side wall cover kit in case of non-flush installation	SKSFK800CS
Joining kit for dual installation	SKSFJ800P
Medium brushed Aluminium Handle – 805 mm	SKSHK310HS
Long brushed Aluminium Handle – 1,218 mm	SKSHK480HS
Replacement water filter	LT1000P-S

SKSCF2411P

Installation Notes

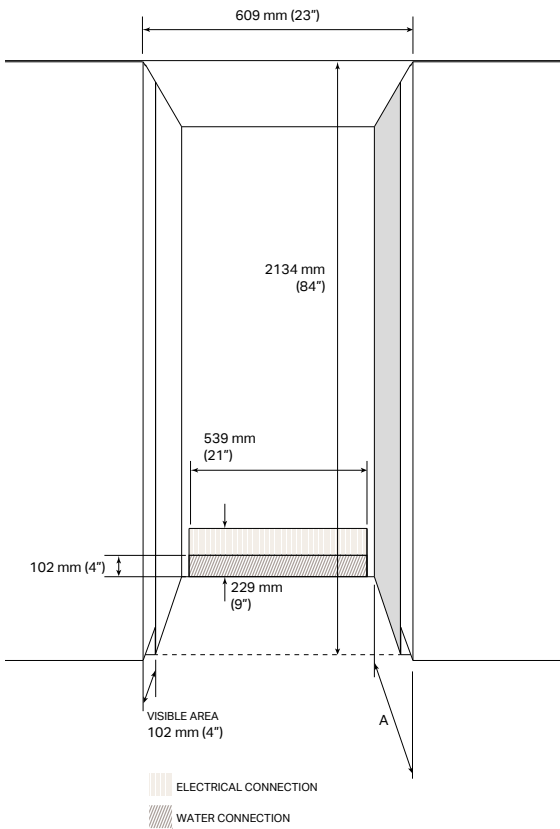

Electrical

230V, 50Hz, 15 or 20° power supply required. It is recommended to set up a three-prong receptacle recessed into the wall and properly earthed, equipped with an individual circuit.

Water connection

A connection to the water mains with a pressure between 1.37 and 8.27 bar (20 and 120 psi) is required. It is recommended to provide a specific cock for closing the circuit, not to be installed directly behind the product for easier accessibility and a pipe (Max Ø 9.5 mm) with a suitable length to reach the front of the freezer of approximately 355 mm, with respect to the front of the kitchen doors. A maximum space of 40 mm from the bottom of the recess is available for the water connection.

Visible area

The indicated area (102 mm) is visible once the refrigerator doors are opened, this area should be finished on both sides.

In case of non-flush installation, we recommend using the **SKSFK800CS** accessory, which consists of side panels that cover any visible side parts of the appliance.

Flush or extended installation

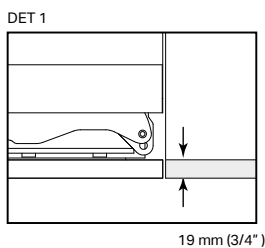
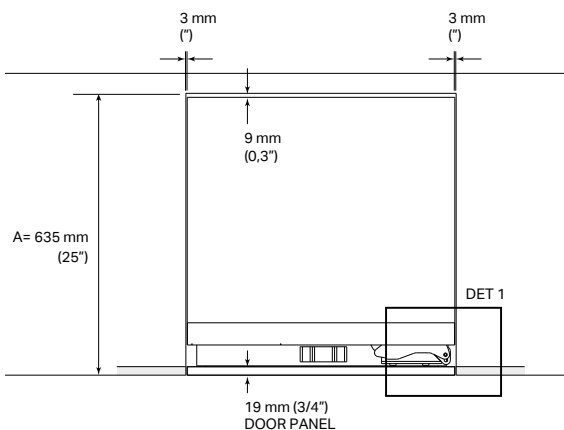

TOP VIEW
FLUSH INSTALLATION

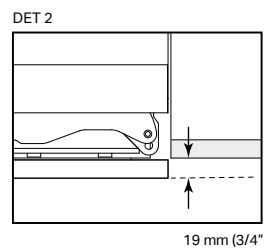
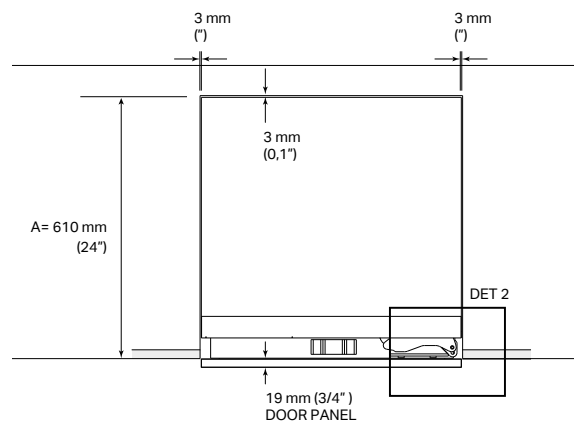

TOP VIEW
EXTENDED INSTALLATION

SKSCF2411P

Custom panels

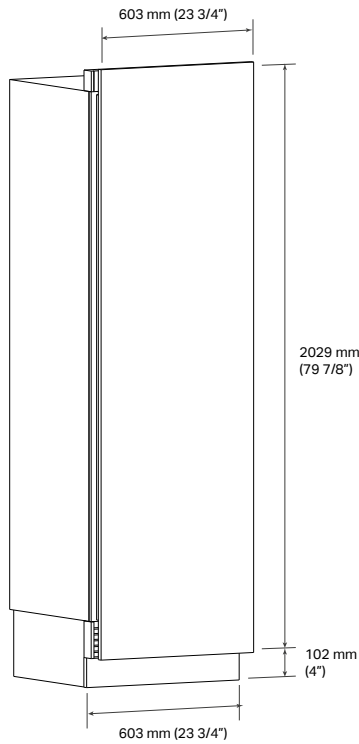

Panel options

SKSPK245CS : Stainless steel panel kit

The appliance can be panelled with the optional Signature Kitchen Suite stainless steel door kit. The kit includes one door panel, one toe kick and one Long handle.

This kit is reversible and can be used in both Right Hand and Left Hand door swing installations.

Custom Panels

The appliance is designed to be customised with panels in line with the kitchen cabinet aesthetics. For the dimensions of custom panels, refer to the diagram and the indications below:

Door panel: 2029 mm x 60 mm

Maximum panel weight permitted: 24 kg

Toe kick: 102 mm x 603 mm

The Signature Kitchen Suite handles, in brushed aluminium, in the medium or long version, can be purchased separately as an accessory.

SKSHK310HS: Medium handles for custom panels

805 mm (31 11/16") Medium handle – Brushed aluminium

SKSHK480HS: Long handles for custom panels

1219 mm (48") Long handle – Shiny brushed aluminium

Custom panel dimensions

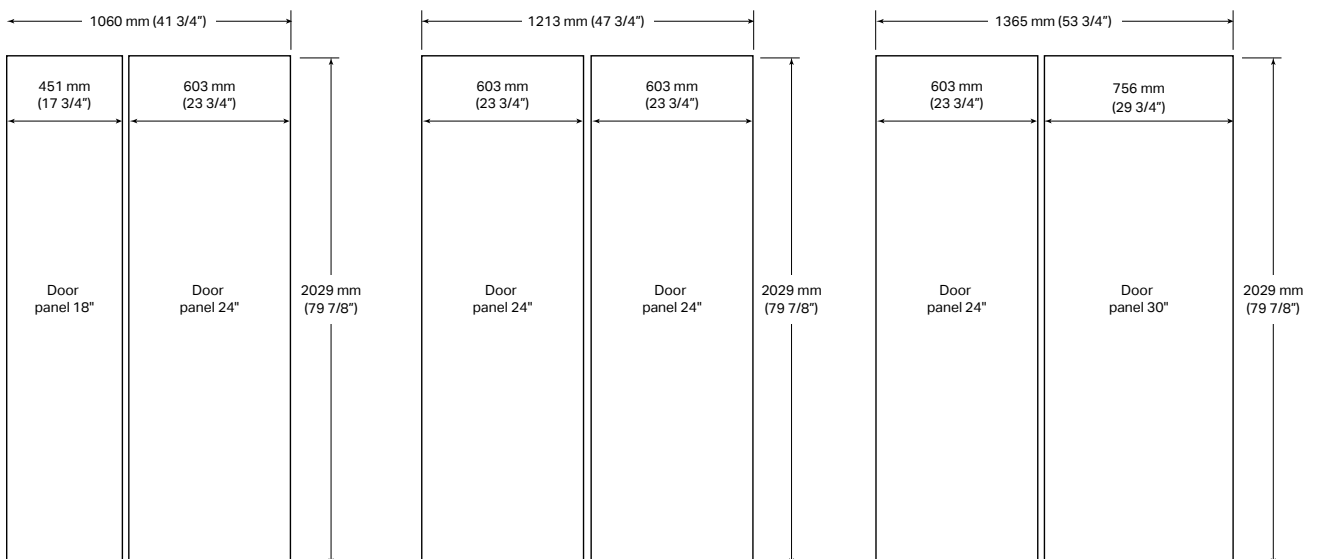

SKSCF2411P

Installation Notes

90° DOOR OPENING

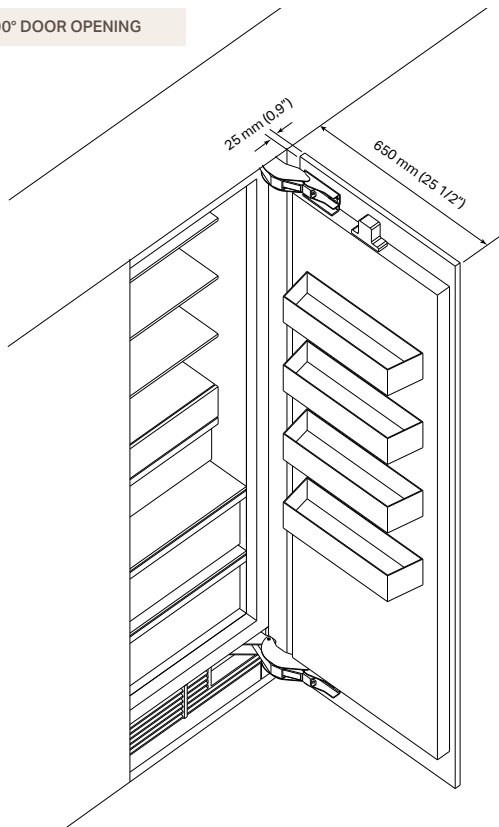

115° DOOR OPENING

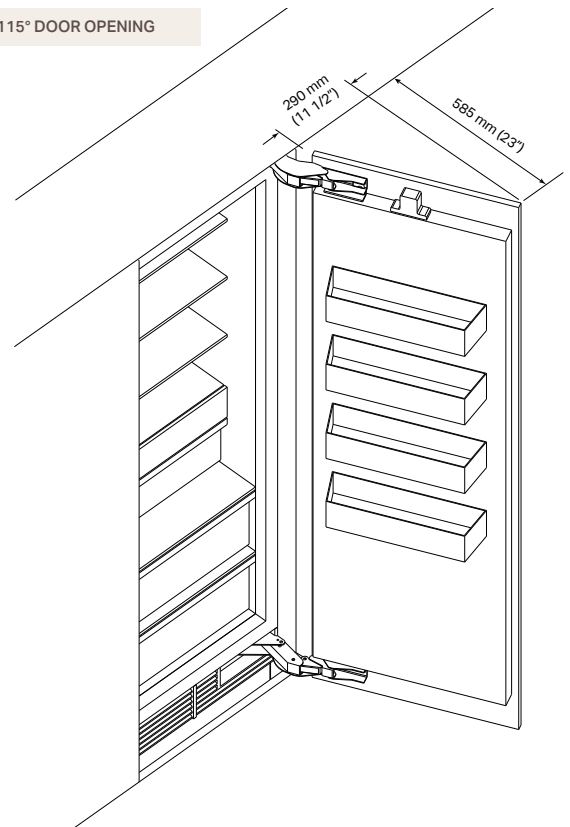

Door clearances with flush installation

The installation must allow for clearances to adjacent walls or cabinets. The factory-set door opening is 115° and can subsequently be adjusted to 90° provided the clearances for opening at 115° are not sufficient.

ATTENTION

The clearance dimensions highlighted in the diagrams DO NOT include the depth of the handles, which must be added to these dimensions in case of a custom extended handle.

When using the Signature Kitchen Suite with brushed aluminium handles, the side clearances change as shown:

90° door
Side clearance from 25 mm to 95 mm

115° door
Side clearance from 290 mm to 360 mm

90° DOOR OPENING

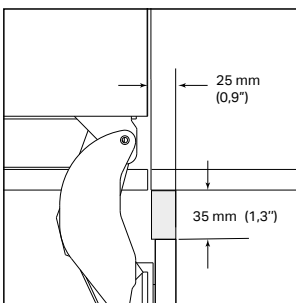

115° DOOR OPENING

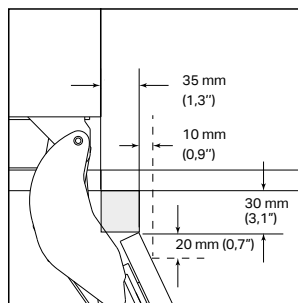

Useful spaces for placing the handle on adjacent cabinets

In case of installation with door opening at 90° for potential placement of an extended handle on the side next to the refrigerator, a handle with a maximum height of 35 mm with respect to the external edge of the panel can be applied for the first 25 mm.

In case of installation with door opening at 115° for potential placement of an extended handle on the side next to the Column freezer 24", a handle with a maximum height of 30 mm with respect to the external edge of the panel can be applied for the first 35 mm.

A handle can be applied with a 20 mm increment in length for every additional 10 mm increment in distance from the flush cabinet.



SKSCF1811P

Integrated column freezer 18"

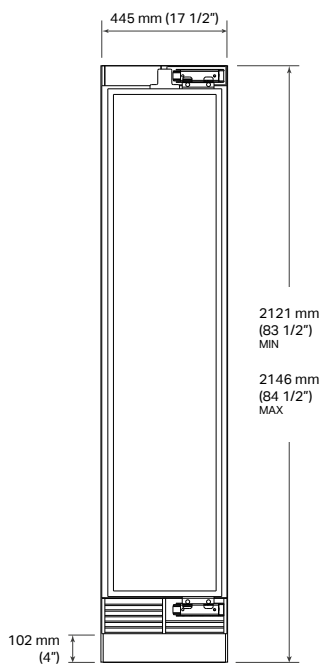

FRONT VIEW

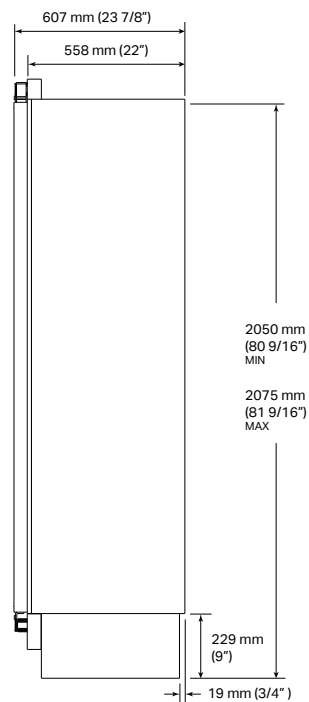

SIDE VIEW

SKSCF1811P

Model	EAN: 8806091454935
Door type	Panel ready
Hinges	Plat
Internal finish	Stainless steel
Energy Label	
Energy efficiency class	F
Net total capacity	274 L
Maximum sound level	< 39 dbA Max
ENERGY STAR® Qualified	●
Yearly total energy consumption (kW/h)	323
Climate class	SN-T
Classification	****
General Properties	
No-Frost	●
Inverter Linear compressor	●
Wi-Fi enabled for SmartThinQ® control with iOS/Android app	●
Automatic Adaptive Defrost	●
Functions that can be enabled from the control panel	Water Filter, Ice Plus, Ice On/Off, Door Alarm, Wi-Fi, Power On/Off, Demo, Smart Diagnosis™, Temp control
Speed Freeze	●
Connection to the water supply	●
Water Filter (6 Months)	●
Storage shelves	3 adjustable and removable
True-View® Lighting	●
Lift and Go™ ice drawer	1 with telescopic guides and soft closing
Lift and Go™ storage drawers	2 with telescopic guides and soft closing
Aluminium door bins with removable inserts	4 cantilever
Removable ice bucket capacity	2.3 kg
Digital Controls w/ White LED Display	●
Water Filter Indicator	●
Ice production (24 Hours)	1.6 kg
Ice On / Off	●
Operating temperatures	from -24°C to -16°C
Installation	
Reversible Door	●
Four point front adjustable with 6 wheels	●
Attachment method to cabinetry	Top with no visible screws
Front Serviceable	●
Anti-tip Bracket Included	●
Unification Kit Included (SKSFJ800P)	●
Technical Specifications	
Required power supply	230 V, 50 Hz
Power cord length	2200 mm (86.6")
Overall width	445 mm (17 1/2")
Overall height	2121 mm (83 1/2") MIN ~ 2146 mm (84 1/2") MAX
Overall depth	607 mm (23 7/8")
Net weight	138 kg
Shipping weight	159 kg
Max packaged product dimensions	2290x504x678 mm
Accessories	
Stainless steel panel / handle / toe kick kit	SKSPK185CS
Side wall cover kit in case of non-flush installation	SKSFK800CS
Joining kit for dual installation	SKSFJ800P
Medium brushed Aluminium Handle – 805 mm	SKSHK310HS
Long brushed Aluminium Handle – 1,218 mm	SKSHK480HS
Replacement water filter	LT1000P-S

SKSCF1811P

Installation Notes

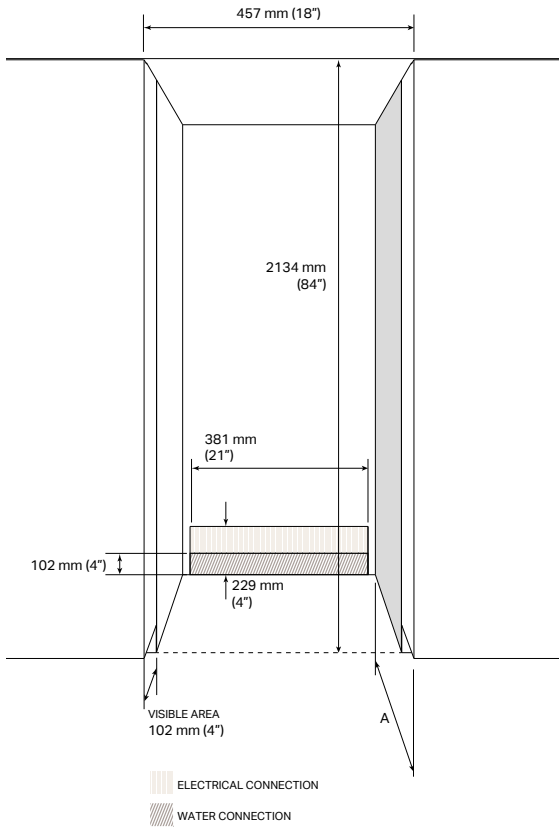

Electrical

230V, 50Hz, 15 or 20° power supply required. It is recommended to set up a three-prong receptacle recessed into the wall and properly earthed, equipped with an individual circuit.

Water connection

A connection to the water mains with a pressure between 1.37 and 8.27 bar (20 and 120 psi) is required. It is recommended to provide a specific cock for closing the circuit, not to be installed directly behind the product for easier accessibility and a pipe (Max Ø 9.5 mm) with a suitable length to reach the front of the freezer of approximately 355 mm, with respect to the front of the kitchen doors. A maximum space of 40 mm from the bottom of the recess is available for the water connection.

Visible area

The indicated area (102 mm) is visible once the refrigerator doors are opened, this area should be finished on both sides.

In case of non-flush installation, we recommend using the **SKSFK800CS** accessory, which consists of side panels that cover any visible side parts of the appliance.

Flush or extended installation

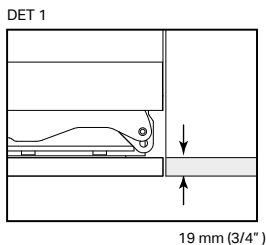
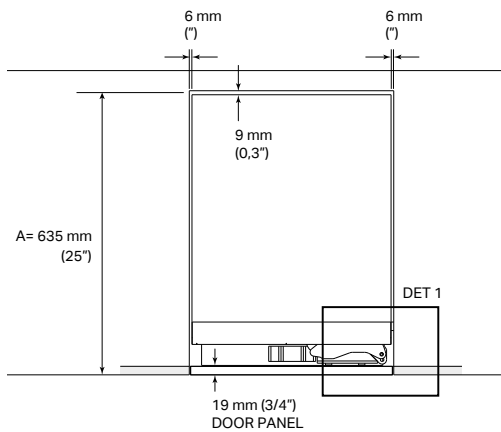

TOP VIEW
FLUSH INSTALLATION

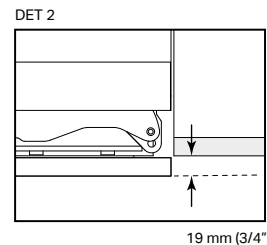
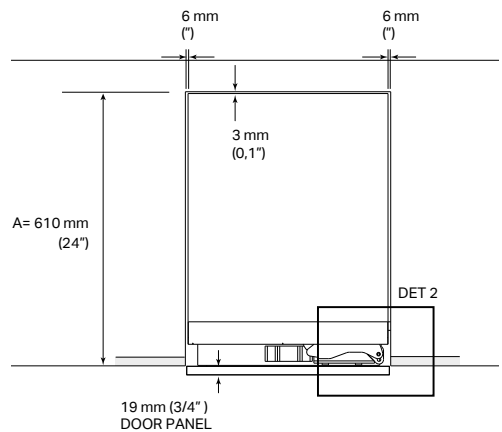

TOP VIEW
EXTENDED INSTALLATION

SKSCF1811P

Custom panels

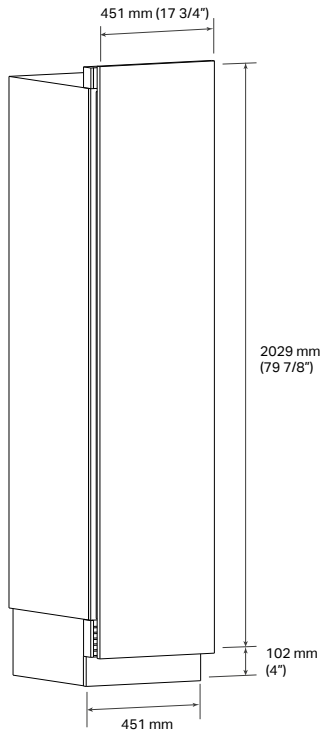

Panel options

SKSPK185CS : Stainless steel panel kit

The appliance can be panelled with the optional Signature Kitchen Suite stainless steel door kit. The kit includes one door panel, one toe kick and one Long handle.

This kit is reversible and can be used in both Right Hand and Left Hand door swing installations.

Custom Panels

The appliance is designed to be customised with panels in line with the kitchen cabinet aesthetics. For the dimensions of custom panels, refer to the diagram and the indications below:

Door panel: 2029 mm x 457 mm

Maximum panel weight permitted: 20 kg

Toe kick: 102 mm x 457 mm

The Signature Kitchen Suite handles, in brushed aluminium, in the medium or long version, can be purchased separately as an accessory

SKSHK310HS: Medium handles for custom panels

805 mm (31 11/16") Medium handle – Brushed aluminium

SKSHK480HS: Long handles for custom panels

1219 mm (48") Long handle – Shiny brushed aluminium

Custom panel dimensions

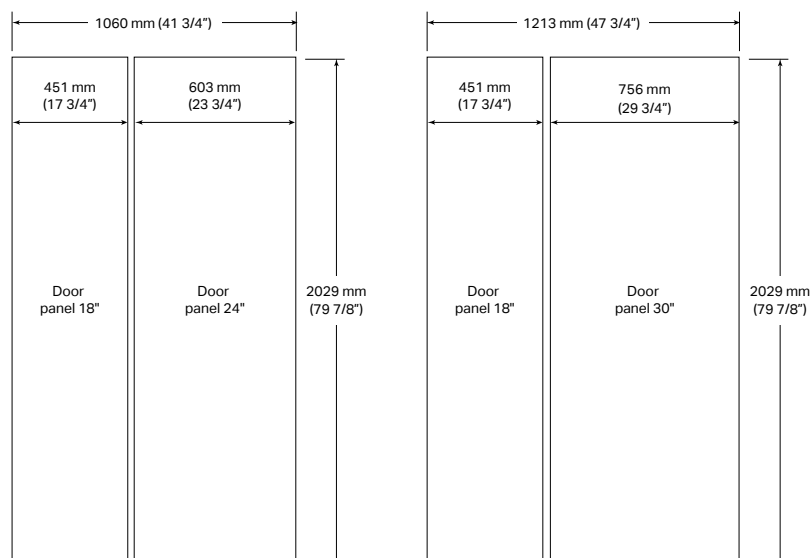

SKSCF1811P

Installation Notes

90° DOOR OPENING

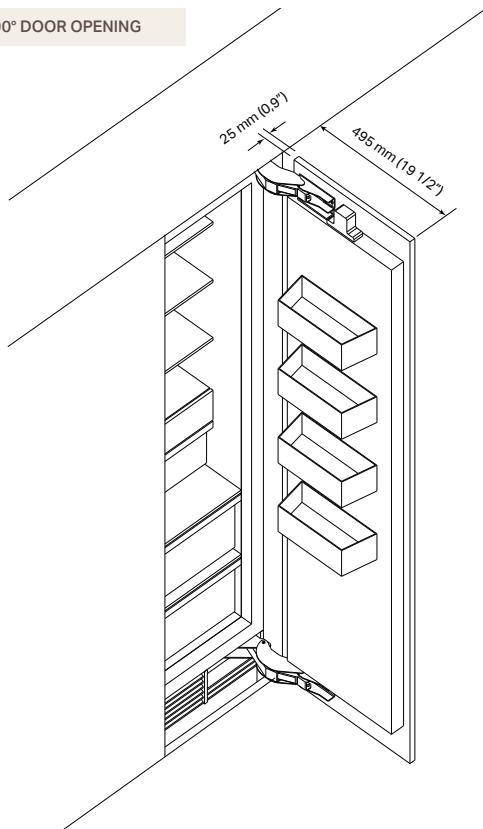

115° DOOR OPENING

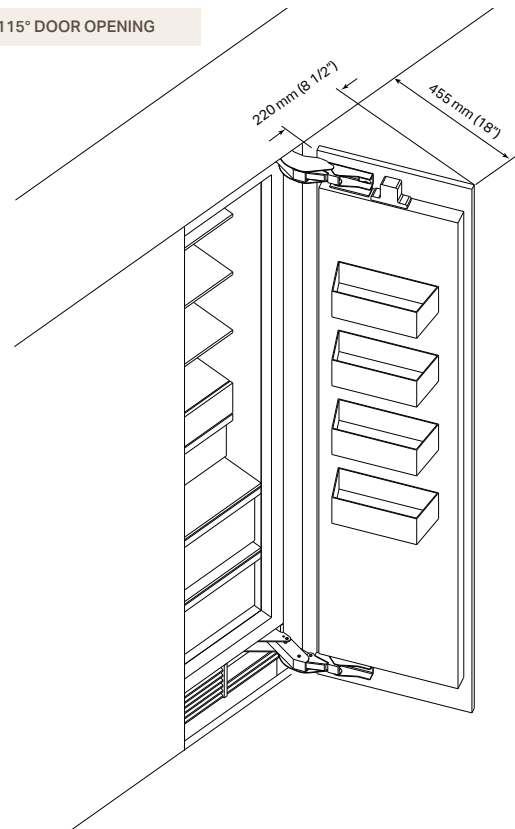

Door clearances with flush installation

The installation must allow for clearances to adjacent walls or cabinets. The factory-set door opening is 115° and can subsequently be adjusted to 90° provided the clearances for opening at 115° are not sufficient.

ATTENTION

The clearance dimensions highlighted in the diagrams DO NOT include the depth of the handles, which must be added to these dimensions in case of a custom extended handle.

When using the Signature Kitchen Suite with brushed aluminium handles, the side clearances change as shown:

90° door
Side clearance from 25 mm to 95 mm

115° door
Side clearance from 220 mm to 290 mm

90° DOOR OPENING

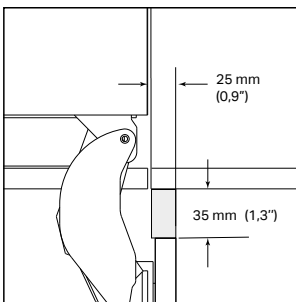

115° DOOR OPENING

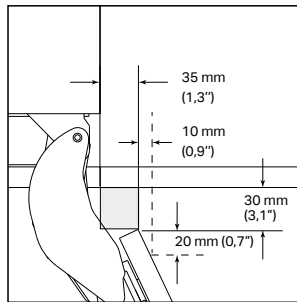

Useful spaces for placing the handle on adjacent cabinets

In case of installation with door opening at 90° for potential placement of an extended handle on the side next to the Column freezer 18", a handle with a maximum height of 35 mm with respect to the external edge of the panel can be applied for the first 25 mm.

In case of installation with door opening at 115° for potential placement of an extended handle on the side next to the Column freezer 18", a handle with a maximum height of 30 mm with respect to the external edge of the panel can be applied for the first 35 mm.

A handle can be applied with a 20 mm increment in length for every additional 10 mm increment in distance from the flush cabinet.

True Benefits

Inverter Linear compressor

The Inverter Linear compressor guarantees less wear than traditional compressors, for longer life and optimal performance. It is very quiet since it does not contain mechanical components between the engine and piston, but only 1 point of friction in its operation compared to the traditional 4. It offers an energy savings of 60% with respect to traditional compressors, as it adapts cooling to the actual needs of use.



Bright interiors

The interiors of the freezers are entirely coated in stainless steel: they are not only beautiful to look at, but ensure better hygiene and a constant refrigeration temperature in order to keep the ingredients fresher for longer. The high quality and sturdy transparent ABS shelves allow you to see inside of them, ensuring easier identification even of small-sized products.



SMART TIP

SMART CONNECTION

Column freezers are Wi-Fi ready and can be connected to the LG ThinQ app for remote function management: changing the temperatures, checking the filter status, setting Ice Plus. The app can be used to verify correct operation through Smart Diagnosis™ and receive an alert in the event of a sudden shutdown in order to promptly intervene.



Refrigeration

Undercounter convertible refrigerator

The Undercounter convertible refrigerator is a unique product on the market.

In fact, it consists of two compartments: the upper refrigerator drawer and the lower convertible drawer. The latter can be set in six different temperature modes, ranging from a minimum of -23°C to a maximum of $+10^{\circ}\text{C}$.

True Benefits

Flexible temperatures

The Undercounter convertible refrigerator is a unique product within its category. It consists of two drawers of which: the upper one, which can be set with five temperature modes ranging from -3°C to 10°C, the lower one which can be converted into a freezer and which can be set with six temperature modes (from -23°C to 10°C).



Panel ready drawers

The Undercounter convertible refrigerator drawers support stainless steel panels, which can be purchased as accessories, or with custom finishes. The panel dimensions differ between the two drawers.



Noiseless and ideal for bedrooms, small rooms and living rooms

The Undercounter convertible refrigerator is extremely noiseless (37 dBA max) and comes with ENERGY STAR® certification: these characteristics make it an extremely versatile appliance, which can fit in any room of the house as well as in different settings, from hotel rooms to yachts.



SMART TIP

CONTROL PANEL

All settings can be modified from here, controlling the temperature of each drawer separately. The display has been placed at the handle of the upper drawer, to ensure easy accessibility and maximum user comfort. The display is equipped with a lock button to prevent the settings from being changed during normal use of the handle.

SKSUD2402P

Undercounter convertible refrigerator



FRONT VIEW

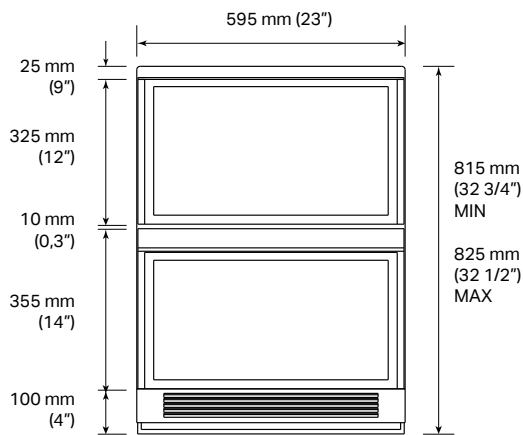

SIDE VIEW

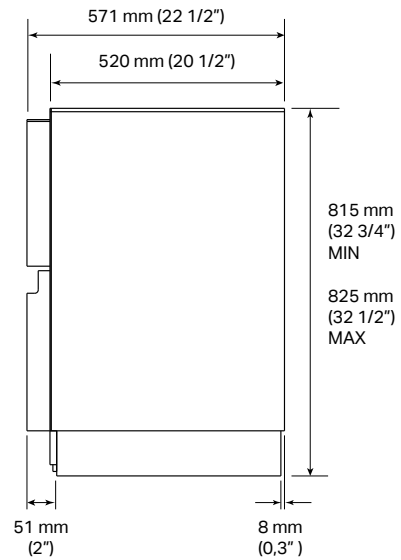

TOP VIEW

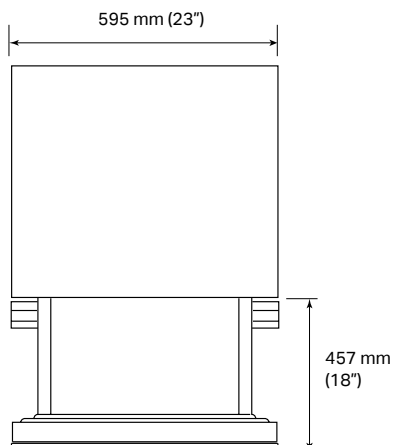

SKSUD2402P

Model	EAN: 8806091740946
Door type	Panel ready
Internal finish	Stainless steel
Energy Label	
Energy efficiency class	F
Net total capacity	89 L
Net refrigerator capacity	43
Net freezer capacity	46
Maximum sound level	< 37 dbA Max
General properties	
ENERGY STAR® Qualified	•
No-Frost	•
Inverter compressor	•
Wi-Fi enabled for SmartThinQ® control with iOS/Android app	•
Automatic Adaptive Defrost	•
Modes	Freezer (-23 C° to -15 C°), Meat (-3 C°), Seafood (1 C°), Bar (1 C°), Refrigerator (2°C to 7 C°), Pantry (10 C°)
Speed Freeze	•
True-View® Lighting	•
Digital Controls w/ White LED Display	•
Operating temperatures	Upper drawer: from -3°C to 10°C Lower drawer: from -23°C to 10°C
Installation	
Reversible Door	•
Four Point Front Adjustable with 4 Wheels	•
Attachment method to cabinetry	Top with no visible screws
Front Serviceable	•
Anti-tip Bracket Included	•
Technical Specifications	
Overall width	595 mm (23")
Overall height	815 mm (32 1/2") MIN ~ 825 mm (32 1/2") MAX
Overall depth	571 mm (22 1/2")
Net weight	65 kg
Shipping weight	69 kg
Max packaged product dimensions	970x650x650 mm (38"x25"x25")
Accessories	
Steel doors kit	SKSUK240DS

SKSUD2402P

Installation Notes

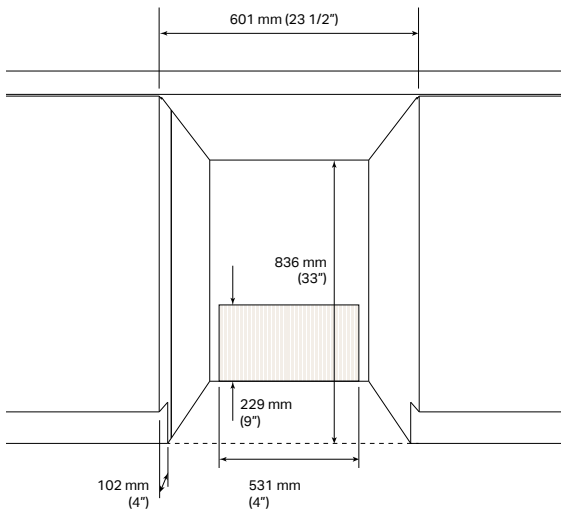

 ELECTRICAL CONNECTION

Electrical

230V, 50Hz, 15 or 20° power supply required. It is recommended to set up a three-prong receptacle recessed into the wall and properly earthed, equipped with an individual circuit.

Visible area

The indicated area (102 mm) is visible once the refrigerator doors are opened, this area should be finished on both sides.

ATTENTION

Should you plan on placing the electrical connection outside the rear part of the cabinet where the product is installed, the product can be installed flush with the front, in a cabinet with a reduced depth of 605 mm.

Flush or extended installation

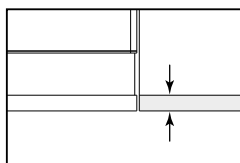
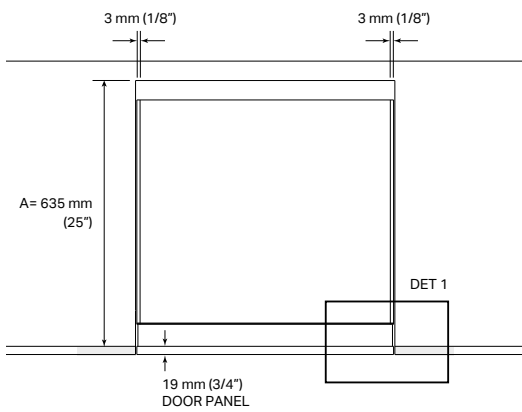

TOP VIEW

FLUSH INSTALLATION

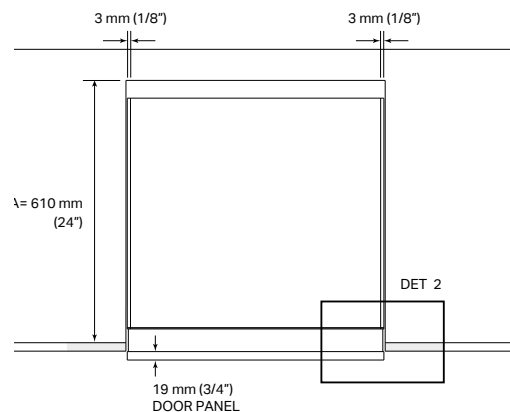

DET 2

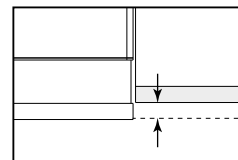

TOP VIEW

EXTENDED INSTALLATION

SKSUD2402P

Custom panels

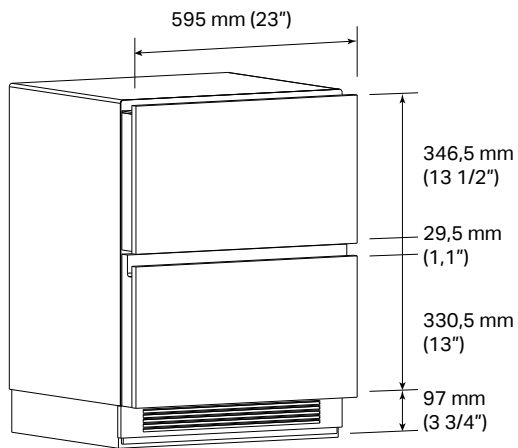

Panel options

SKSUK240DS: Stainless steel panel kit

The appliance can be panelled with the optional Signature Kitchen Suite stainless steel door kit. The kit includes a panel for the upper drawer and one of different height for the lower one.

Custom Panels

The appliance is designed to be customised with panels in line with the kitchen cabinet aesthetics. For the dimensions of custom panels, refer to the diagram and the indications below:

Upper drawer panel - 595mm x 346.5mm

Lower drawer panel - 595mm x 330.5mm

Door clearances with extended installation

UPPER DRAWER OPENING

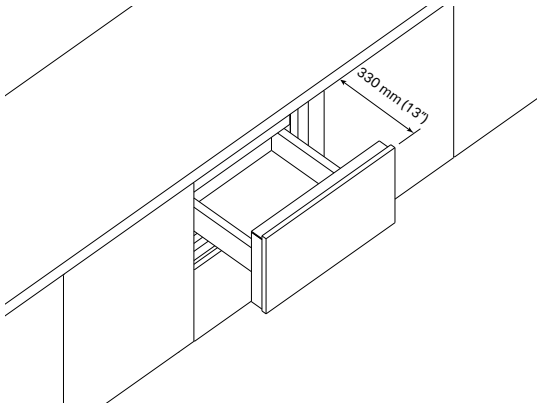

LOWER DRAWER OPENING

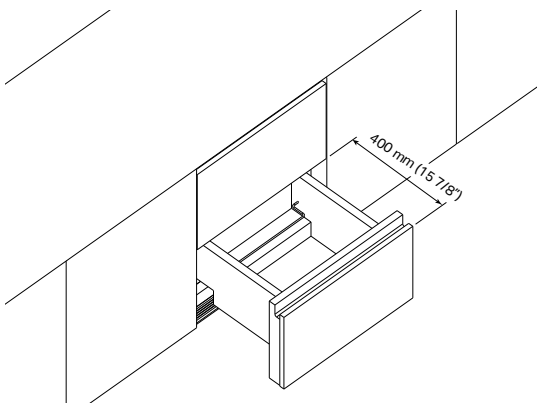

Door clearances with flush installation

The installation must allow for clearances with respect to opposite cabinets.

The values indicated below refer to the mobile edge outside the door including the aesthetic panel, with drawer fully extracted:

Lower drawer: 400 mm

Upper drawer: 330 mm



UNDERCOUNTER CONVERTIBLE REFRIGERATOR

True Benefits

Self close

The Convertible undercounter refrigerator includes the drawer "self close" function which guarantees their automatic closing so as not to compromise the quality and storage of food. Furthermore, thanks to the Inverter compressor, it reduces to a minimum temperature fluctuations within $\pm 1.0^\circ$ to maintain food fresh.



Flexible space

The Convertible undercounter refrigerator offers smart space management solutions. The extra space drawer, positioned in the upper compartment, is dedicated to small-sized foods, while the bottle bar enables for better bottle management.



Interior lighting

The Convertible undercounter refrigerator guarantees optimal internal lighting in all conditions thanks to the exclusive LED light system placed inside the drawer.



SMART TIP

SMART CONNECTION

The Convertible undercounter refrigerator is Wi-Fi ready and can be connected to LG's ThinQ app for remote management of functions. The app can be used to verify correct operation through Smart Diagnosis™ and receive an alert in the event of a sudden shutdown in order to promptly intervene.



Refrigeration

Column wine cellar

Every detail is designed to store your wines as precious jewels: quality materials, lack of vibrations and smart technology to prevent energy dispersion.

The Column wine cellar, integrated and panel ready, is available in two widths, 24" (113 bottles) and 18" (71 bottles).

True Benefits

Separate temperature zones

The Wine cellars feature 3 zones (24" model) or 2 zones (18" model), adjustable for temperature and humidity, each equipped with a dedicated evaporator and dividing barriers which guarantee perfect cold-air circulation and enable to simultaneously store different types of wine: for example sparkling wines (6° - 10°C), sweet white wines (6° - 8°C), full-bodied white wines or light reds (10° - 13°C), aged reds (13° - 18°C), vintage port (18°-20°C).



Natural beech wood shelves and steel profiles

The 10 natural beech wood shelves are solid to the touch, they give stability and help eliminate odours and substances that can alter wine properties and naturally regulate internal temperature and humidity. The stainless steel profiles slide smoothly on the telescopic guides, limiting the vibrations transmitted to the bottles as much as possible. They are supplied as standard with two (24") or one (18") stand for tilted storage. All internal profiles have a dark grey finish.



Smart Knock Door

The Smart Knock Door technology enables to activate the internal lighting without opening the door, by knocking twice on the outer glass. This way it is possible to view your bottles and choose the most suitable wine without affecting conservation and preventing temperature and energy dispersion.



SMART TIP

CONTROL PANEL

It enables to easily manage all settings, from adjusting the temperature and humidity of the different temperature zones, to the lighting. The door open alarm is also located here.

SKSCW242RP

Integrated column wine cellar 24"

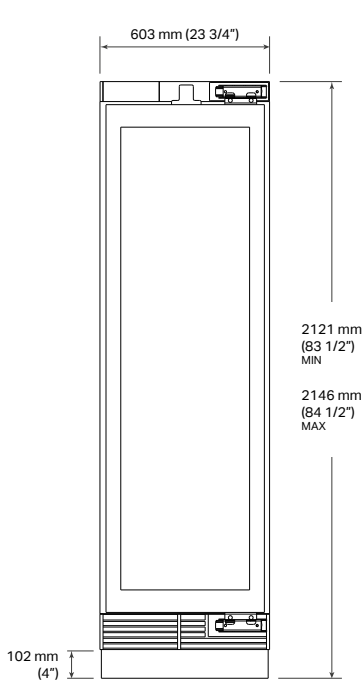

FRONT VIEW

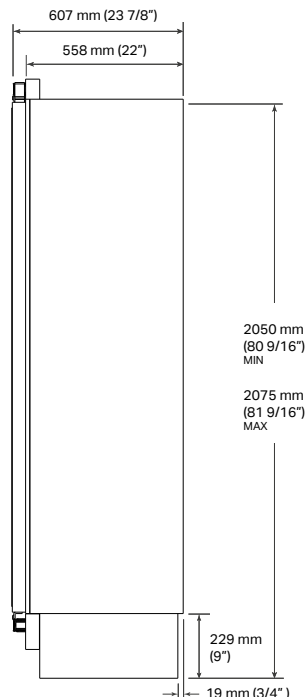

SIDE VIEW

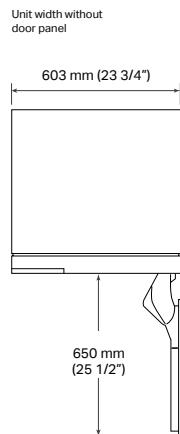

90° DOOR OPENING

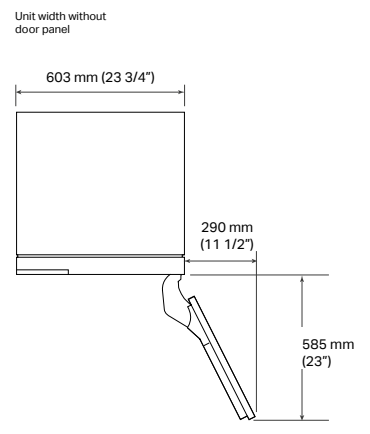

115° DOOR OPENING

SKSCW242RP

Model	EAN: 8806091454997
Door type	Panel ready
Hinges	Plat
Internal finish	Stainless steel
Energy Label	
Energy efficiency class	G
Bottle Capacity (750 ml)	113
Maximum sound level	< 37 dbA Max
Yearly total energy consumption (kW/h)	189
Climate class	SN-T
General Properties	
No-Frost	●
Inverter Linear compressor	●
Wi-Fi enabled for SmartThinQ® control with iOS/Android app	●
InstaView™ Window (Knock Twice to See Inside)	●
Wine Cave Technology™	●
Temperature zones	3
Operating temperatures	from 5°C to 18°C
Functions that can be enabled from the control panel	Humidity, Lighting, Demo, Power On / Off, Temp Control, Smart Diagnosis™, Wi-Fi
Humidity Control	●
High Altitude Compatibility	●
Anti-vibration motor	●
UV Protection	●
Storage shelves	10
Shelf material	Natural beech wood with stainless steel profiles
Presenter Shelves	2
True-View® Lighting	●
Presenter Shelf Lighting	●
Installation	
Reversible Door	●
Four point front adjustable with 6 wheels	●
Attachment method to cabinetry	Top with no visible screws
Front Serviceable	●
Anti-tip Bracket Included	●
Technical Specifications	
Required power supply	230 V, 50 Hz
Power cord length	2197 mm (86.4")
Plug type	A 3
Overall width	603 mm (23 3/4")
Overall height	2121 mm (83 1/2") MIN ~ 2146 mm (84 1/2") MAX
Overall depth	607 mm (23 7/8")
Net weight	162 kg
Shipping weight	182 kg
Max packaged product dimensions	2290x663x678 mm (90"x25"x26")
Accessories	
Stainless steel panel / handle / toe kick kit	SKSWK245RS (RIGHT HINGE, LEFT HANDLE) SKSWK245LS (LEFT HINGE, RIGHT HANDLE)
Side wall cover kit in case of non-flush installation	SKSFK800CS
Joining kit for dual installation	SKSFJ800P
Medium brushed Aluminium Handle – 805 mm	SKSHK310HS
Long brushed Aluminium Handle – 1,218 mm	SKSHK480HS

SKSCW242RP

Installation Notes

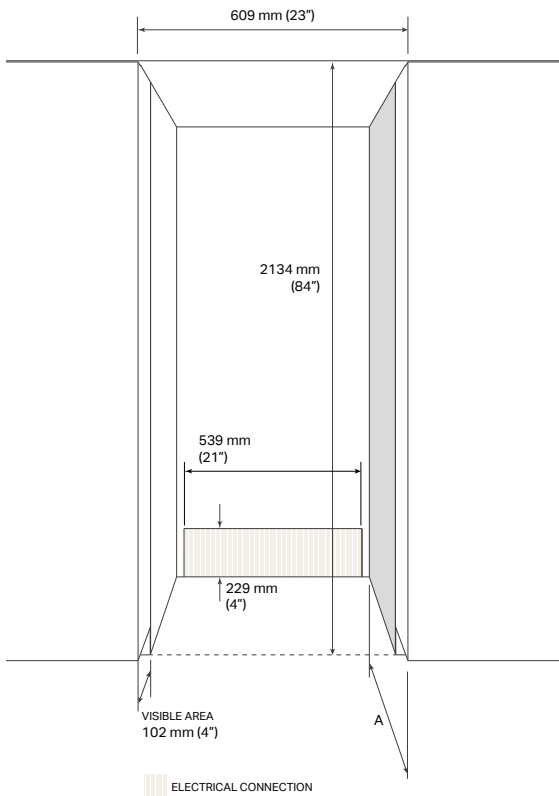

Electrical

230V, 50Hz, 15 or 20° power supply required. It is recommended to set up a three-prong receptacle recessed into the wall and properly earthed, equipped with an individual circuit.

Visible area

The indicated area (102 mm) is visible once the refrigerator doors are opened, this area should be finished on both sides.

Flush or extended installation

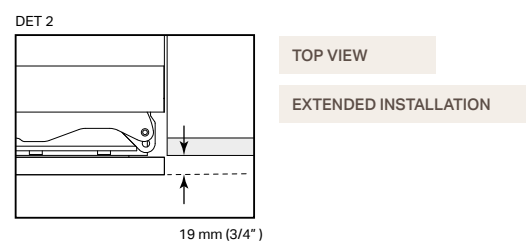
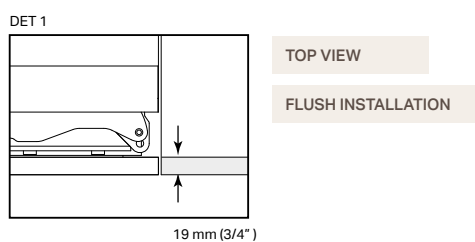
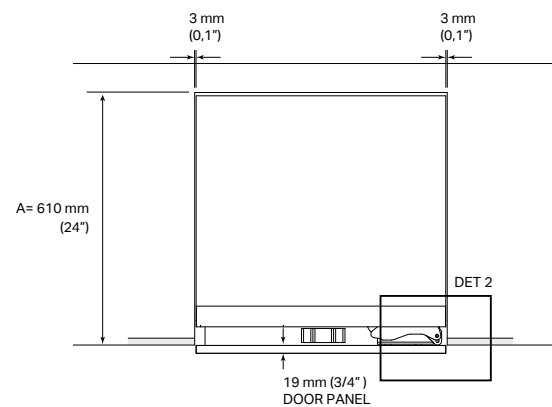
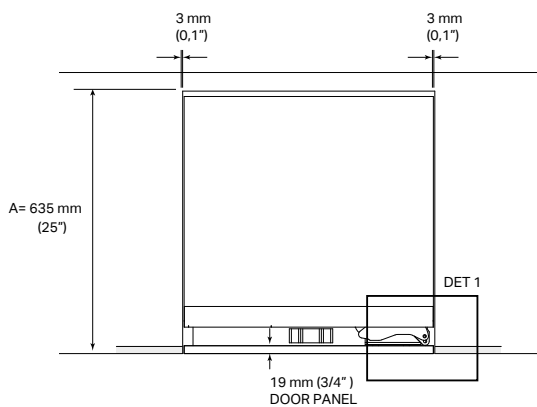

SKSCW242RP

Custom panels

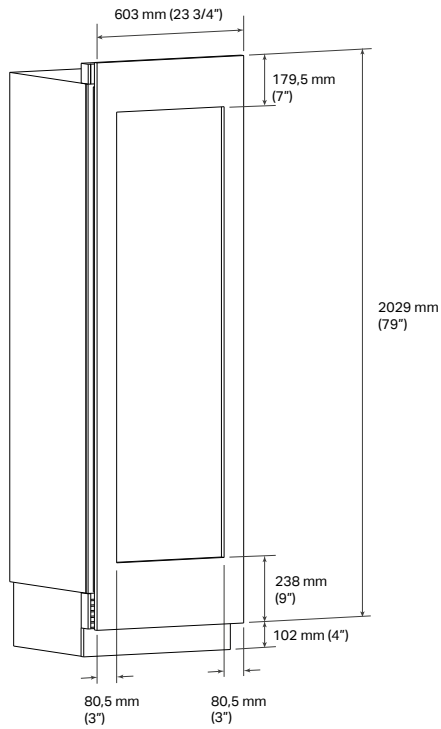

Panel options

SKSWK245RS: Kit with right hinge stainless steel panel

SKSWK245LS: Kit with left hinge stainless steel panel

The appliance can be panelled with the optional Signature Kitchen Suite stainless steel door kit. The kit includes one door panel, one toe kick and one Long handle.

Custom Panels

The appliance is designed to be customised with panels in line with the kitchen cabinet aesthetics. For the dimensions of custom panels, refer to the diagram and the indications below:

Door panel: 2029 mm x 603 mm

Maximum panel weight permitted: 10 kg

The central part of the door is fitted with glass to enable to view inside the product.

Provide for a door panel with a central area unloaded with respect to the edges as indicated below:

Upper 779.5 mm

Lower 238 mm

Side 80.5 mm

Toe kick: 702 mm x 603 mm

The Signature Kitchen Suite handles, in brushed aluminium, in the medium or long version, can be purchased separately as an accessory.

SKSHK310HS: Medium handles for custom panels

805 mm (31 11/16") Medium handle – Brushed aluminium

SKSHK480HS: Long handles for custom panels

1219 mm (48") Long handle – Shiny brushed aluminium

Installation Notes

90° DOOR OPENING

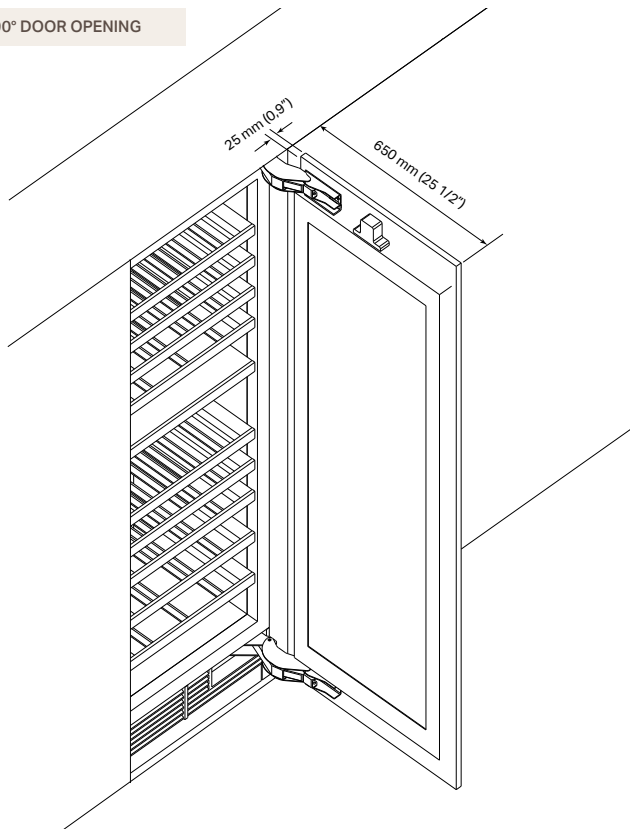

115° DOOR OPENING

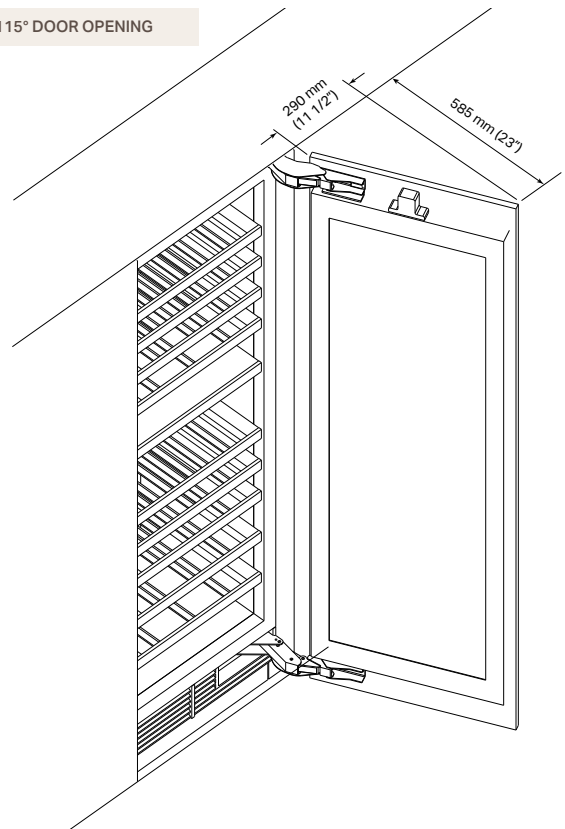

Door clearances with flush installation

The installation must allow for clearances to adjacent walls or cabinets. The factory-set door opening is 115° and can subsequently be adjusted to 90° provided the clearances for opening at 115° are not sufficient.

ATTENTION

The clearance dimensions highlighted in the diagrams DO NOT include the depth of the handles, which must be added to these dimensions in case of a custom extended handle.

When using the Signature Kitchen Suite with brushed aluminium handles, the side clearances change as shown:

90° door

Side clearance from 25 mm to 95 mm

115° door

Side clearance from 290 mm to 360 mm

90° DOOR OPENING

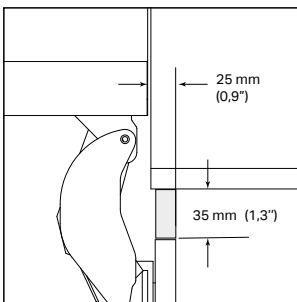

115° DOOR OPENING

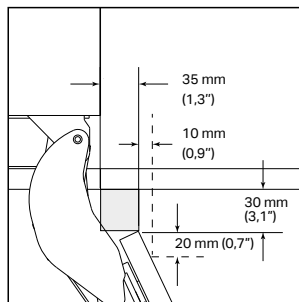

Useful spaces for placing the handle on adjacent cabinets

In case of installation with door opening at 90° for potential placement of an extended handle on the side next to the Column freezer 18", a handle with a maximum height of 35 mm with respect to the external edge of the panel can be applied for the first 25 mm.

In case of installation with door opening at 115° for potential placement of a extended handle on the side next to the Column freezer 18", a handle with a maximum height of 30 mm with respect to the external edge of the panel can be applied for the first 35 mm.

The appliance includes the possibility of inverting the hinge side and therefore the door opening side. Even in the event of door reversal, the clearances remain the same as previously indicated.

A handle can be applied with a 20 mm increment in length for every additional 10 mm increment in distance from the flush cabinet.

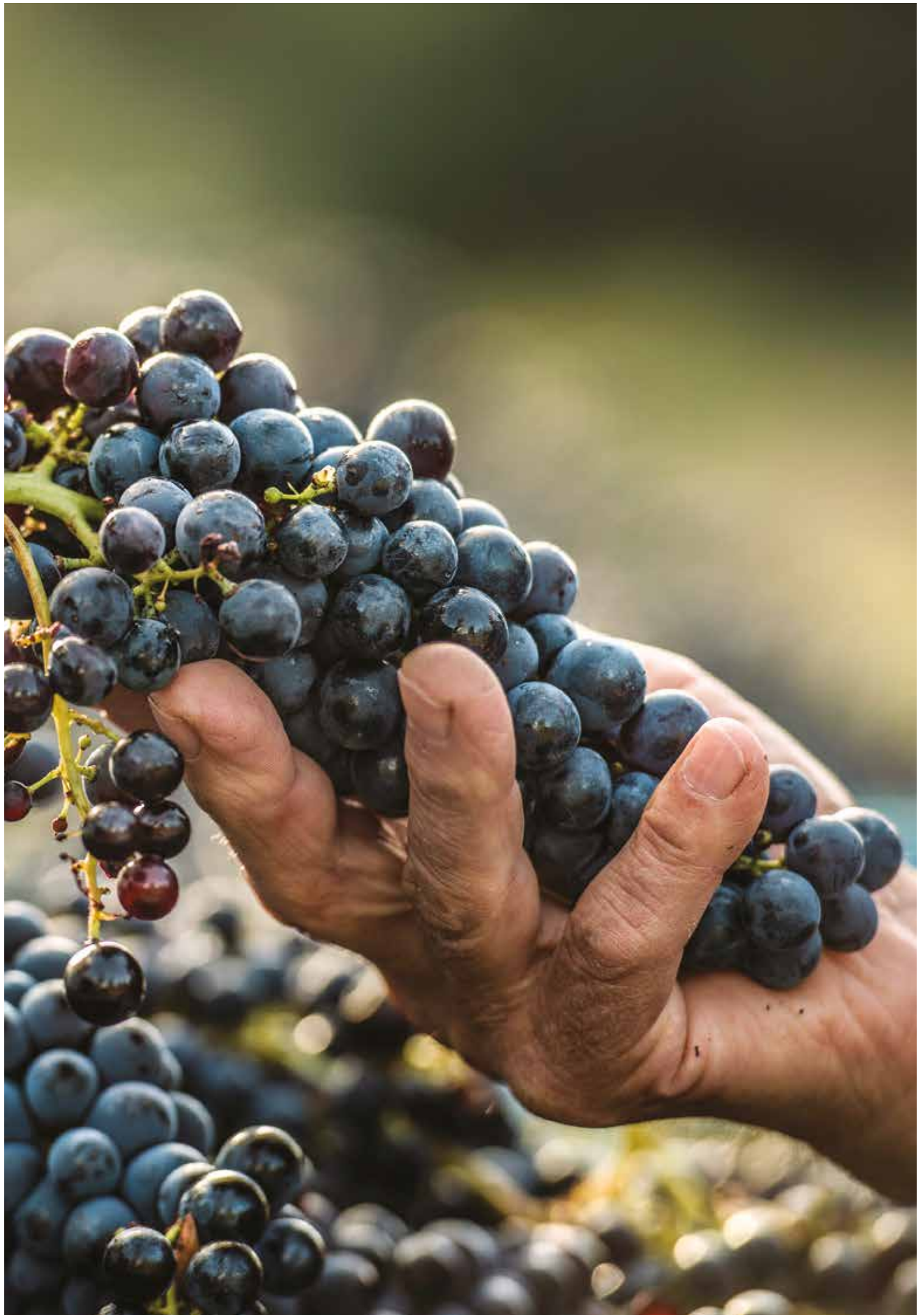

SKSCW182RP

Integrated column wine cellar 18"

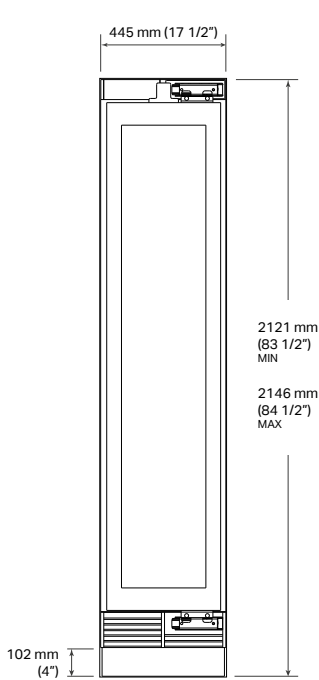

FRONT VIEW

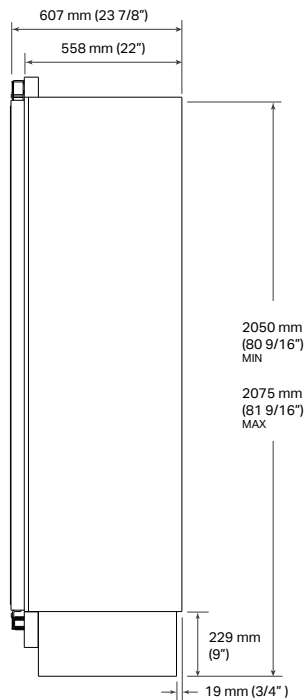

SIDE VIEW

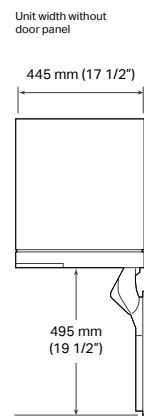

90° DOOR OPENING

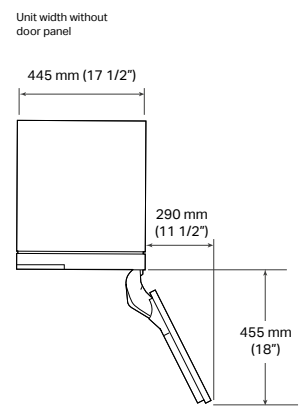

115° DOOR OPENING

SKSCW182RP

Model	EAN: 8806091454980
Door type	Panel ready
Hinges	Plat
Internal finish	Stainless steel
Energy Label	
Energy efficiency class	G
Bottle Capacity (750 ml)	71
Maximum sound level	< 37 dbA Max
Yearly total energy consumption (kW/h)	165
Climate class	SN-T
General Properties	
No-Frost	●
Inverter Linear compressor	●
Wi-Fi enabled for SmartThinQ® control with iOS/Android app	●
InstaView™ Window (Knock Twice to See Inside)	●
Wine Cave Technology™	●
Temperature zones	2
Operating temperatures	from 5°C to 18°C
Functions that can be enabled from the control panel	Humidity, Lighting, Demo, Power On / Off, Temp Control, Smart Diagnosis™, Wi-Fi
Humidity Control	●
High Altitude Compatibility	●
Anti-vibration motor	●
UV Protection	●
Storage shelves	10
Shelf material	Natural beech wood with stainless steel profiles
Presenter Shelves	1
True-View® Lighting	●
Presenter Shelf Lighting	●
Installation	
Reversible Door	●
Four point front adjustable with 6 wheels	●
Attachment method to cabinetry	Top with no visible screws
Front Serviceable	●
Anti-tip Bracket Included	●
Technical Specifications	
Required power supply	230 V, 50 Hz
Power cord length	2197 mm (86.4")
Plug type	A 3
Overall width	445 mm (17 1/2")
Overall height	2121 mm (83 1/2") MIN ~ 2146 mm (84 1/2") MAX
Overall depth	607 mm (23 7/8")
Net weight	139 kg
Shipping weight	160 kg
Max packaged product dimensions	2290x504x678 mm
Accessories	
Stainless steel panel / handle / toe kick kit	SKSWK185RS (RIGHT HINGE, LEFT HANDLE) SKSWK185LS (LEFT HINGE, RIGHT HANDLE)
Side wall cover kit in case of non-flush installation	SKSFK800CS
Joining kit for dual installation	SKSFJ800P
Medium brushed Aluminium Handle – 805 mm	SKSHK310HS
Long brushed Aluminium Handle – 1,218 mm	SKSHK480HS

SKSCW182RP

Installation Notes

Electrical

230V, 50Hz, 15 or 20° power supply required. It is recommended to set up a three-prong receptacle recessed into the wall and properly earthed, equipped with an individual circuit.

Visible area

The indicated area (102 mm) is visible once the refrigerator doors are opened, this area should be finished on both sides.

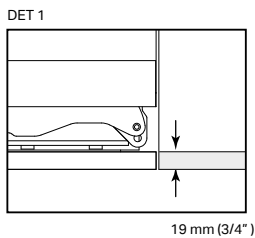
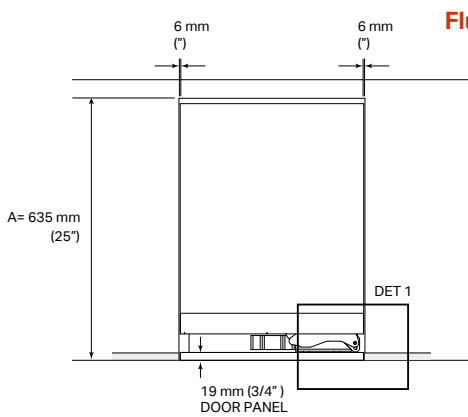
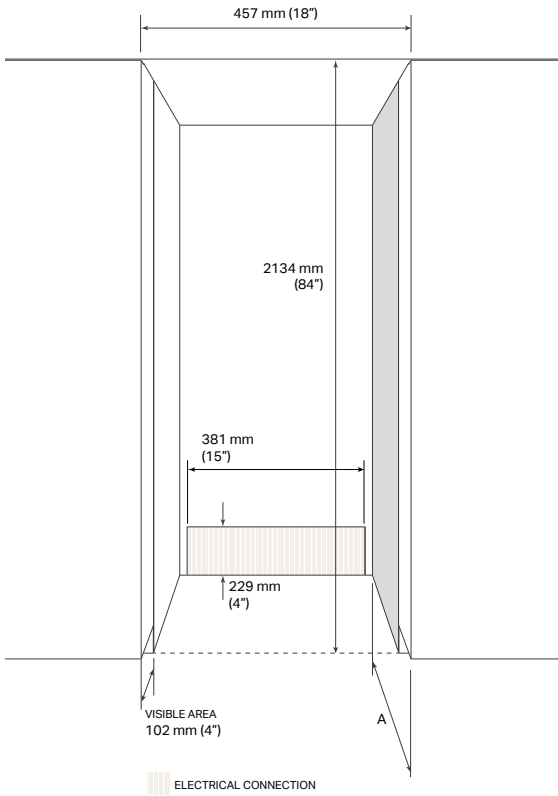

TOP VIEW
FLUSH INSTALLATION

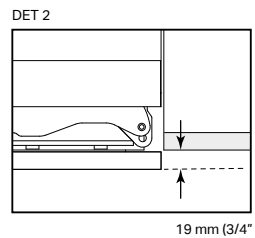
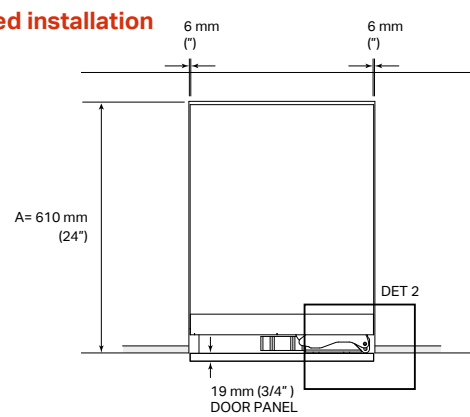

TOP VIEW
EXTENDED INSTALLATION

SKSCW182RP

Custom panels

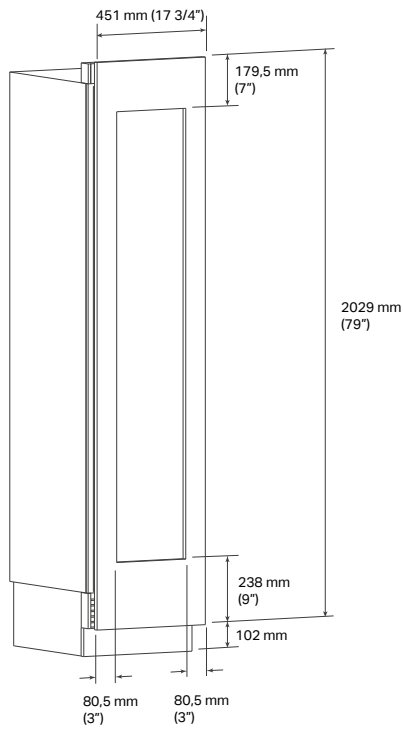

Panel options

SKSWK185RS: Kit with right hinge stainless steel panel

SKSWK185LS: Kit with left hinge stainless steel panel

The appliance can be panelled with the optional Signature Kitchen Suite stainless steel door kit. The kit includes one door panel, one toe kick and one Long handle.

Custom Panels

The appliance is designed to be customised with panels in line with the kitchen cabinet aesthetics. For the dimensions of custom panels, refer to the diagram and the indications below:

Door panel: 2029 mm x 451mm

Maximum panel weight permitted: 9.5 kg

The central part of the door is fitted with glass to enable to view inside the product.

Provide for a door panel with a central area unloaded with respect to the edges as indicated below:

Upper: 779.5 mm

Lower: 238 mm

Side: 80.5 mm

Toe kick: 702 mm x 603 mm

The Signature Kitchen Suite handles, in brushed aluminium, in the medium or long version, can be purchased separately as an accessory .

SKSHK310HS: Medium handles for custom panels

805 mm (31 11/16") Medium handle – Brushed aluminium

SKSHK480HS: Long handles for custom panels

1219 mm (48") Long handle – Shiny brushed aluminium

SKSCW182RP

Installation Notes

90° DOOR OPENING

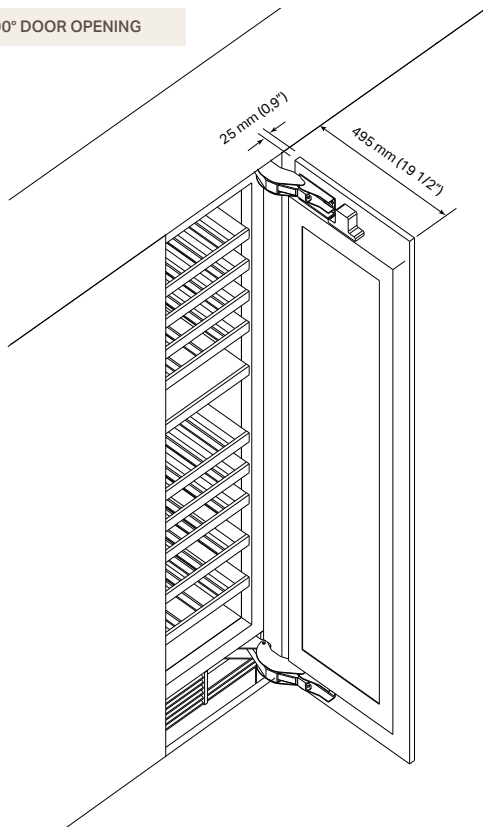

115° DOOR OPENING

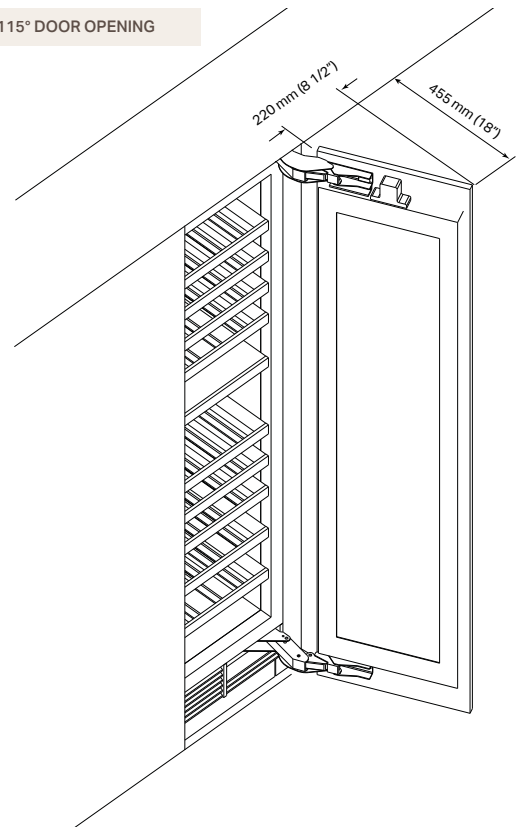

Door clearances with flush installation

The installation must allow for clearances to adjacent walls or cabinets. The factory-set door opening is 115° and can subsequently be adjusted to 90° provided the clearances for opening at 115° are not sufficient.

ATTENTION

The clearance dimensions highlighted in the diagrams DO NOT include the depth of the handles, which must be added to these dimensions in case of a custom extended handle.

When using the Signature Kitchen Suite with brushed aluminium handles, the side clearances change as shown:

90° door

Side clearance from 25 mm to 95 mm

115° door

Side clearance from 290 mm to 360 mm

90° DOOR OPENING

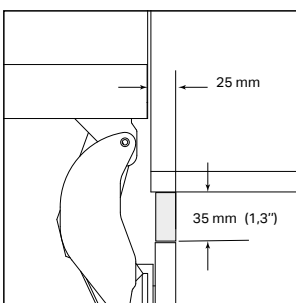

115° DOOR OPENING

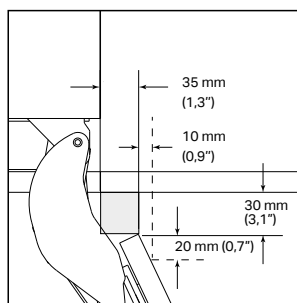

Useful spaces for placing the handle on adjacent cabinets

In case of installation with door opening at 90° for potential placement of an extended handle on the side next to the Column freezer 18", a handle with a maximum height of 35 mm with respect to the external edge of the panel can be applied for the first 25 mm.

In case of installation with door opening at 115° for potential placement of an extended handle on the side next to the Column freezer 18", a handle with a maximum height of 30 mm with respect to the external edge of the panel can be applied for the first 35 mm.

The appliance includes the possibility of inverting the hinge side and therefore the door opening side. Even in the event of door reversal, the clearances remain the same as previously indicated.

A handle can be applied with a 20 mm increment in length for every additional 10 mm increment in distance from the flush cabinet.

True Benefits

Adjustable lighting

It is possible to activate the Presentation Light mode, which leaves the lighting always on even with the door closed. The light can then be adjusted, for each individual zone, to a low, medium or high level, as needed. This function can also be set remotely via the ThinQ app.



Inverter Linear compressor

Inverter Compressor:

The Smart Inverter compressor is designed to provide the best performance with minimum noise and energy consumption. Thanks to the Inverter controller, the compressor only operates at the required, variable speed. The downsized design make it perfect to fit in the Undercounter units.

The controller has been designed to withstand fluctuations in the Voltage from the power line, ensuring there will be no damage or cooling performance reduction.



SMART TIP

SMART CONNECTION

The Column wine cellar is Wi-Fi ready and can be connected to LG's ThinQ app for remote management of functions. The app can be used to verify correct operation through Smart Diagnosis™ in order to promptly intervene. It is possible to set notifications that warn when it is opened: if storing valuable bottles, the system can also be used as a safety device.



Refrigeration

Undercounter wine cellar

The highest wine storage performance in a versatile, compact and elegant product.

The Undercounter wine cellar has been designed to reproduce the ideal wine environment: the Wine Cave Technology™ reduces temperature fluctuations and vibrations to a minimum, guaranteeing the maximum protection from those elements that could compromise product quality.

UNDERCOUNTER WINE CELLAR

True Benefits

Two temperature, light and humidity zones

The Undercounter wine cellar is equipped with two zones whose temperature and humidity can be adjusted separately, each with a dedicated evaporator and stainless steel dividing barrier. This way, different types of wine can be stored at the same time and at the most correct temperature.



Distinctive all-glass design

The Undercounter wine cellar features a smart design, with a handle-less door in opaque triple glass that protects the bottles from UV rays, preventing potential alterations caused by light.



Capacity up to 41 bottles

The four natural beech wood shelves with stainless steel profiles can hold up to 41 bottles. These high quality materials contribute to storage, ensuring the bottles remain stable, helping eliminate odours and substances that may alter wine properties and naturally regulate internal temperature and humidity.



SMART TIP

CONTROL PANEL

It enables to easily manage all settings, from adjusting the temperature and humidity of the different temperature zones, to the lighting. The door open alarm is also located here.

SKSUW2401G

Undercounter wine cellar

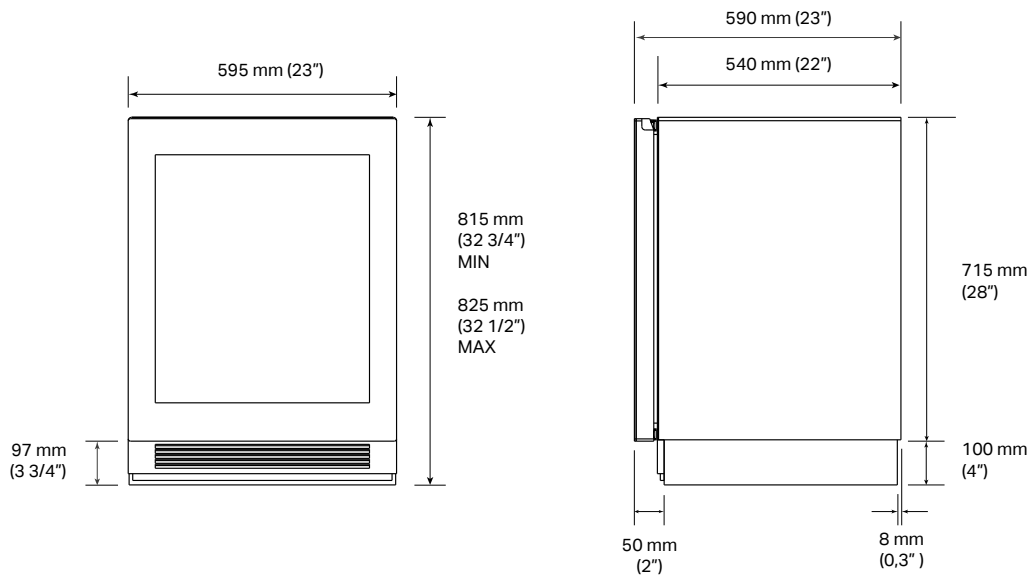

FRONT VIEW

SIDE VIEW

SKSUW2401G

Model	EAN: 8806091740960
Door type (non-reversible)	Glass
Hinges	Plat
Internal finish	Stainless steel
Energy Label	
Energy efficiency class	D
Bottle Capacity (750 ml)	41
Maximum sound level	< 37 dbA Max
General properties	
No-Frost	•
Inverter compressor	•
Wi-Fi enabled for SmartThinQ® control with iOS/Android app	•
Wine Cave Technology™	•
Temperature zones	2
Operating temperatures	from 5°C to 18°C
Functions that can be enabled from the control panel	Demo, Power On / Off, Light On / Off, Lock, Temp Control, Smart Diagnosis™, Wi-Fi
Humidity Control	•
High Altitude Compatibility	•
Anti-vibration motor	•
UV Protection	•
Storage shelves	4
Shelf material	Natural beech wood with stainless steel profiles
Presenter Shelves	•
True-View® Lighting	•
Presenter Shelf Lighting	•
Installation	
Four Point Front Adjustable with 4 Wheels	•
Attachment method to cabinetry	Top with no visible screws
Front Serviceable	•
Anti-tip Bracket Included	•
Reversible Door	NO
Technical Specifications	
Overall width	595 mm (23 1/2")
Overall height	815 mm (32") MIN ~ 825 mm (32 1/2") MAX
Overall depth	590 mm (23")
Net weight	67 kg
Shipping weight	71 kg
Max packaged product dimensions	970x650x650 mm (38"x25"x25")

SKSUD2402P

Installation Notes

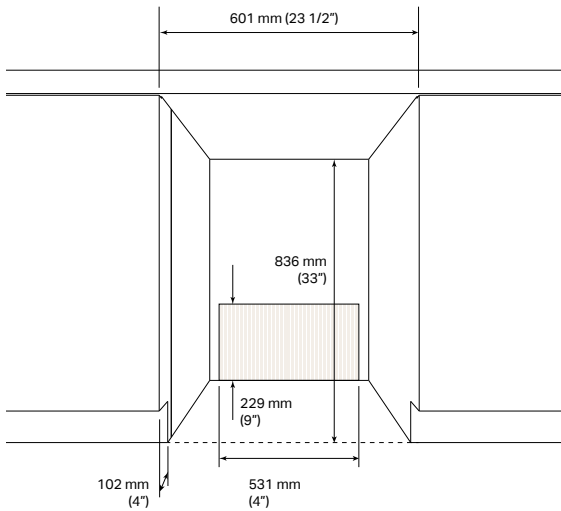

 ELECTRICAL CONNECTION

Electrical

230V, 50Hz, 15 or 20° power supply required. It is recommended to set up a three-prong receptacle recessed into the wall and properly earthed, equipped with an individual circuit.

Visible area

The indicated area (102 mm) is visible once the refrigerator doors are opened, this area should be finished on both sides.

ATTENTION

Should you plan on placing the electrical connection not in the rear part of the cabinet where the product is installed, but outside it, the product can be installed the front edge, in a cabinet with a reduced depth of 605 mm.

NOTES

The product can also be placed at a column height. The product can be installed in a column with the undercounter refrigerator (however dividing the two products with a support shelf).

Flush or extended installation

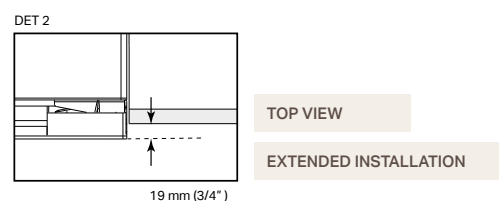
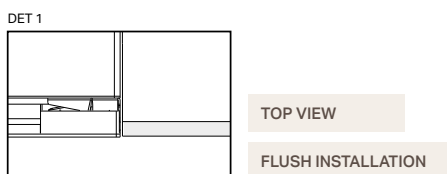
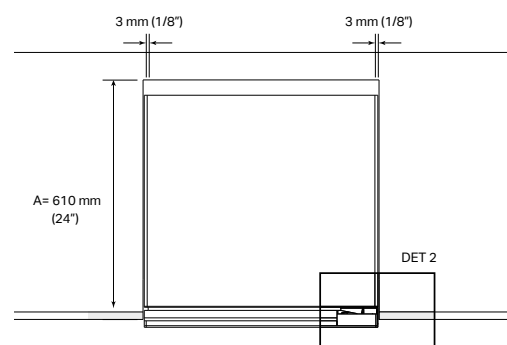
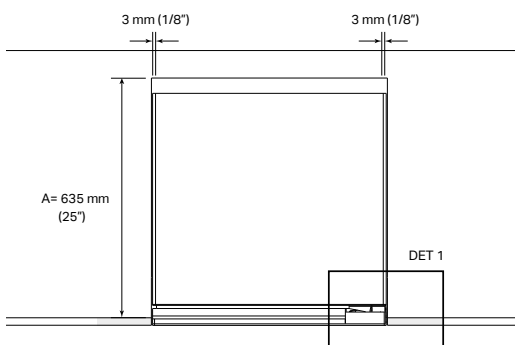

SKSUD2402P

Door clearances with flush installation

UPPER DRAWER OPENING

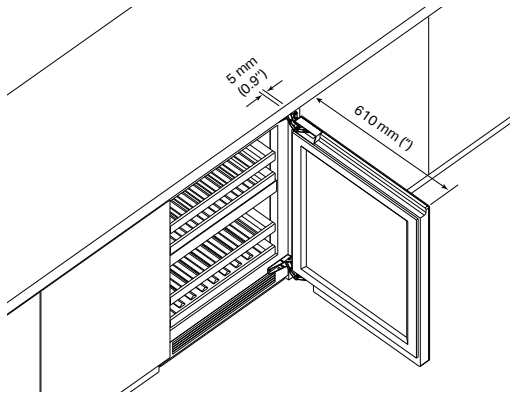

LOWER DRAWER OPENING

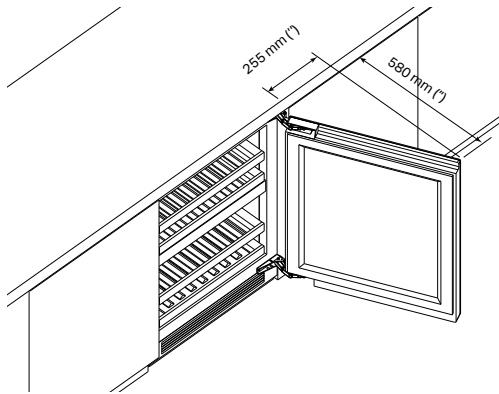

Door clearances with flush installation

The installation must allow for clearances to adjacent walls or cabinets.

The factory-set door opening is 115° and can subsequently be adjusted to 90° provided the clearances for opening at 115° are not sufficient.

ATTENTION

The appliance does NOT include the possibility of inverting the hinge side and therefore the door opening side. Even in the event of door reversal, the clearances remain the same as previously indicated.

Installation Notes

90° DOOR OPENING

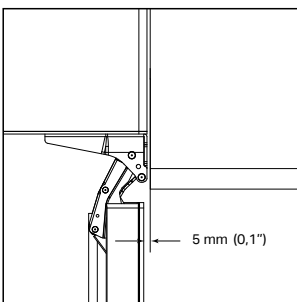

115° DOOR OPENING

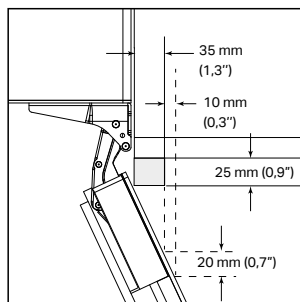

Useful spaces for placing the handle on adjacent cabinets

In case of installation with 90° door opening, the product door is 5 mm away from the adjacent cabinet.

In case of installation with door opening at 115° for potential placement of an extended handle on the side next to the refrigerator, a handle with a maximum height of 25 mm with respect to the external edge of the panel can be applied for the first 35 mm.

A handle can be applied with a 20 mm increment in length for every additional 10 mm increment in distance from the flush cabinet.



True Benefits

Auto open door

The opaque glass door is handle-less with automatic opening via a sensor. Closing also takes place automatically, ensuring there is no energy dispersion.



LED lighting

The Undercounter wine cellar is equipped with two lighting systems, one for each temperature zone.

Once the door is closed, the light switches off to prevent it from having adverse effects on wine storage.

Alternatively, the presentation function can be set, which keeps the lighting on when the door is closed.



Inverter compressor

The Inverter compressor guarantees less wear than traditional compressors, for longer life and optimal performance. It is very quiet since it does not contain mechanical components between the engine and piston, but only 1 point of friction in its operation compared to the traditional 4. It offers an energy savings of 60% with respect to traditional compressors, as it adapts cooling to the actual needs of use.



SMART TIP

SMART CONNECTION

The Undercounter wine cellar is Wi-Fi ready and can be connected to LG's ThinQ app for remote management of functions. The app can be used to verify correct operation through Smart Diagnosis™ in order to promptly intervene.



Refrigeration

Built-in Combinations with cabinets

Refrigerators, Freezers and Wine cellars are combined to obtain customised and professional solutions to be installed inside specific cabinets.

Design Tips

The kitchen is the place where the best ideas are born, this is why Signature Kitchen Suite poses no limits to the customisation of this space: built-in combinations enable us to create countless pairings when it comes to both design and performance to meet all kinds of needs and transform your kitchen into a manifesto of harmony and beauty.

Our cabinets have a linear, clean, essential and harmonious design so they can be placed in all environments and adapt to all kinds of designs and concepts.

They are made of AISI 304 stainless steel with a scotch brite finish - the same of the Signature Kitchen Suite panels that can be ordered as accessories- and help maintain a certain neutrality. Depending on the kitchen design, it is possible to request a specific quote for other types of finishes and countless combinations so that they can fit in with all kinds of interiors.

Installation modes and precautions are the same ones as for individual models, therefore all products can still be wall mounted.

SKS001

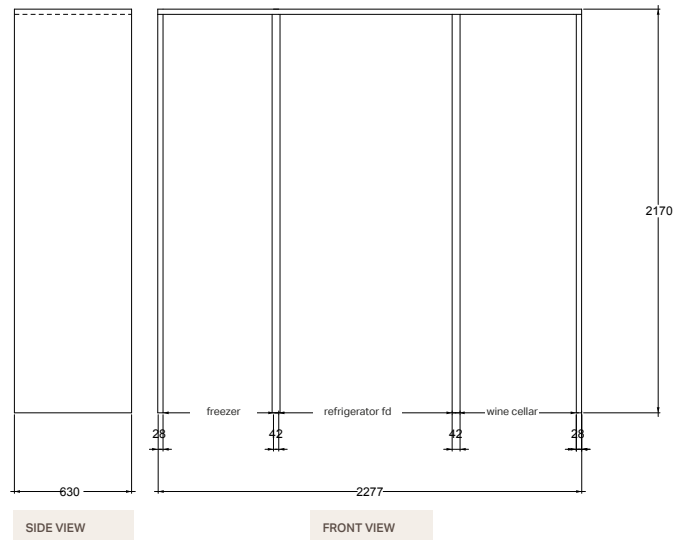

Model	Code
Freezer 24"	SKSCF2411P
French Door 36"	SKSFD3614P
Wine cellar 24"	SKSCW242RP

CABINET COMBINATIONS

SKS 002

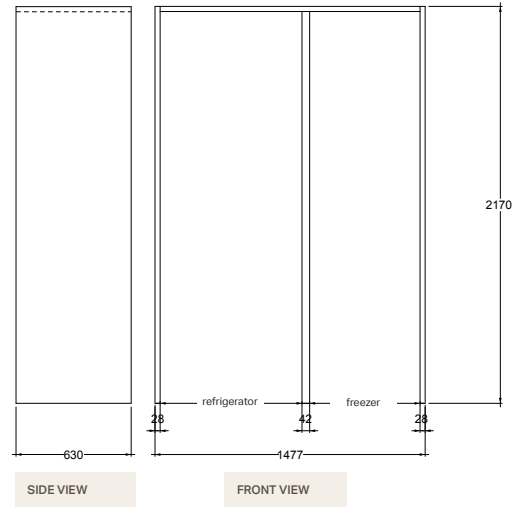

Model	Code
Refrigerator 30"	SKSCR3011P
Freezer 18"	SKSCF1811P

SKS 003

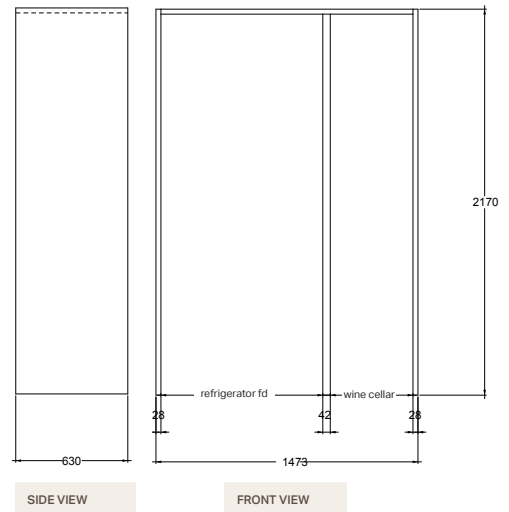

Model	Code
French Door 36"	SKSFD3614P
Wine cellar 18"	SKSCW182RP

CABINET COMBINATIONS

SKSCW182RP-CB

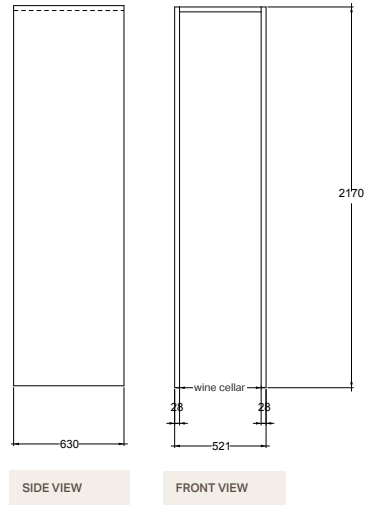

SIDE VIEW

FRONT VIEW

Model

Code

Wine cellar 18"

SKSCW182RP

SKSFD3614P-CB

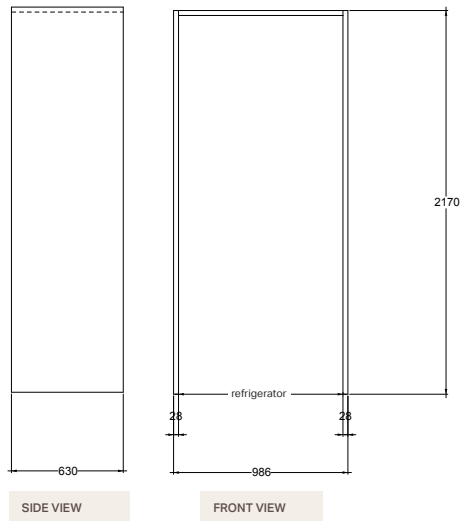

SIDE VIEW

FRONT VIEW

Model

Code

French Door 36"

SKSFD3614P

MULTIPLE COMBINATIONS

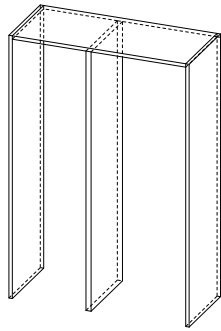

SIDE VIEW

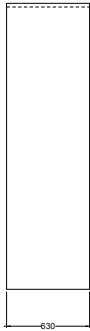

FRONT VIEW

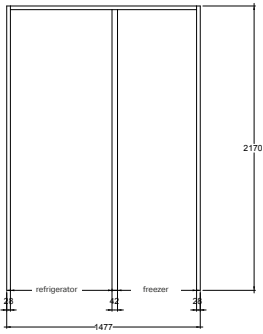

SKS 004*

Model	Code
Refrigerator 30"	SKSCR3011P
Freezer 24"	SKSCF2411P

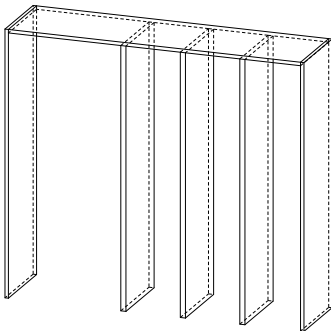

SIDE VIEW

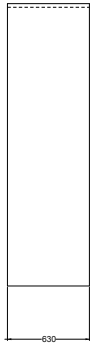

FRONT VIEW

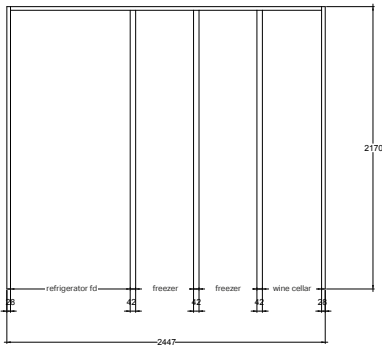

SKS 005

Model	Code
French Door 36"	SKSFD3614P
Freezer 18"	SKSCF1811P
Freezer 18"	SKSCF1811P
Wine cellar 18"	SKSCW182RP

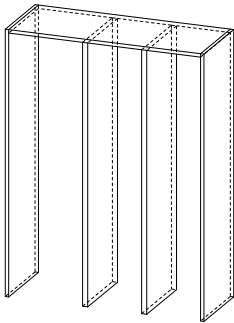

SIDE VIEW



FRONT VIEW

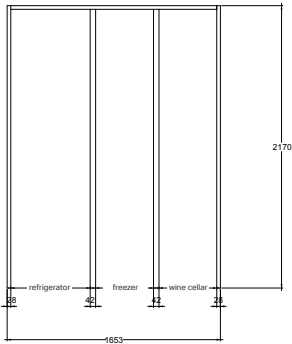

SKS 006

Model	Code
Refrigerator 24"	SKSFD3614P
Freezer 18"	SKSCF1811P
Wine cellar 18"	SKSCW182RP

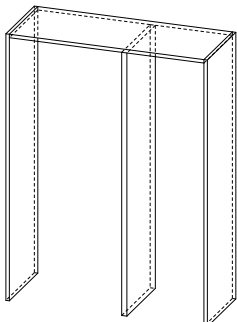

SIDE VIEW



FRONT VIEW

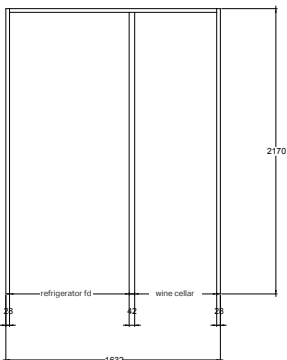

SKS 007*

Model	Code
French Door 36"	SKSFD3614P
Wine cellar 24"	SKSCW242RP

MULTIPLE COMBINATIONS

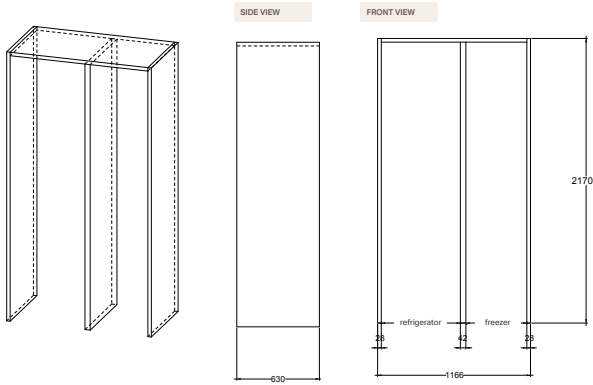

SKS 008

Model	Code
Refrigerator 24"	SKSFD3614P
Freezer 18"	SKSCF1811

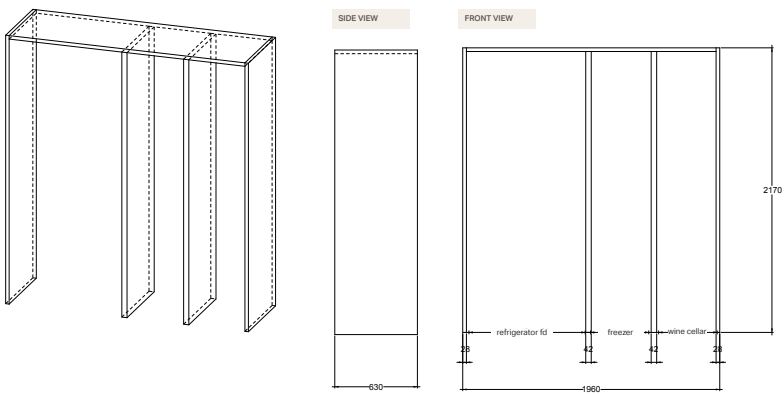

SKS 009

Model	Code
French Door 36"	SKSFD3614P
Freezer 18"	SKSCF1811P
Wine cellar 18"	SKSCW182RP

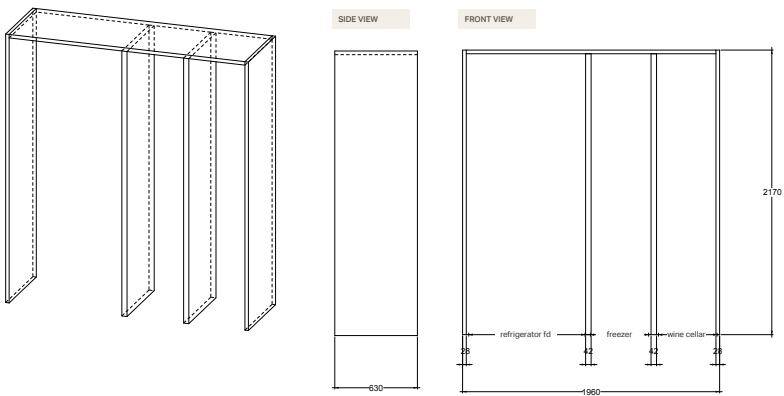

SKS 010

Model	Code
French Door 36"	SKSFD3614P
Freezer 18"	SKSCF1811P
Wine cellar 18"	SKSCW182RP

SINGLE CABINETS

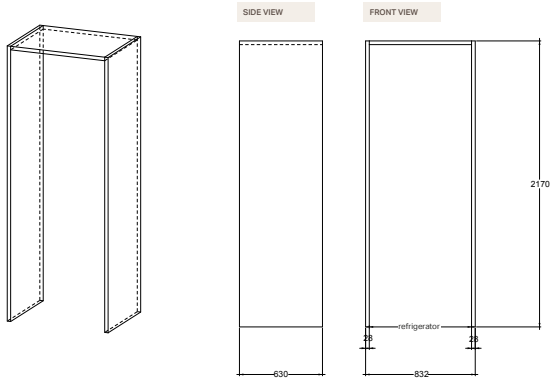

SKSCR3011P-CB

Model	Code
Refrigerator 30"	SKSCR3011P

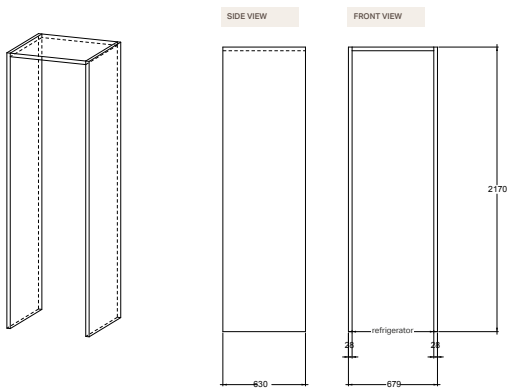

SKSCR2411P-CB

Model	Code
Refrigerator 24"	SKSCR2411P

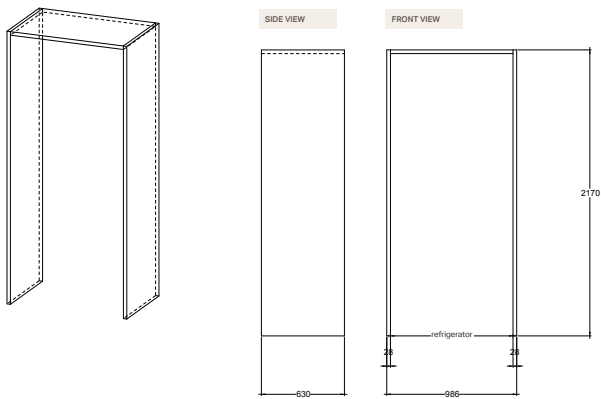

SKSFD3614P-CB

Model	Code
French Door 36"	SKSFD3614P

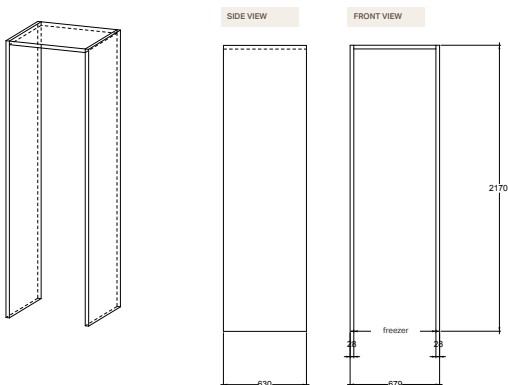

SKSCF2411P-CB

Model	Code
Freezer 24"	SKSCF2411P

SINGLE CABINETS

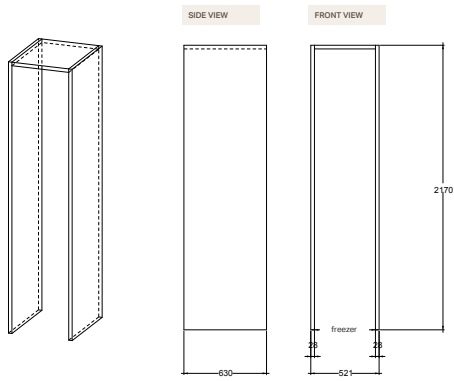

SKSCF1811P-CB

Model	Code
Freezer 18"	SKSCF1811P

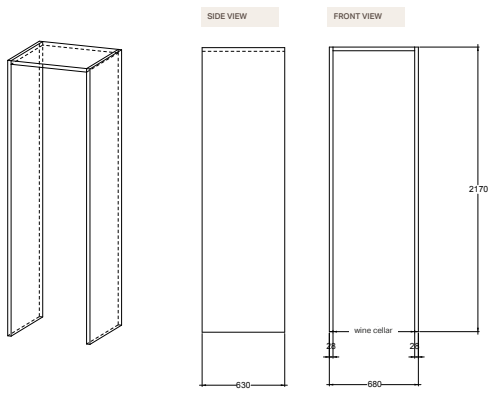

SKSCW242RP-CB

Model	Code
Wine cellar 24"	SKSCW242RP

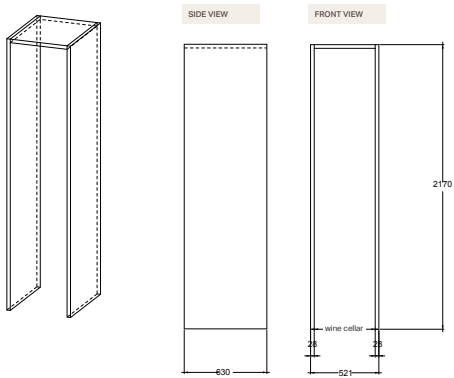

SKSCW182RP-CB

Model	Code
Wine cellar 18"	SKSCW182RP









Cooking

The passion for food continues in your kitchen. This is where the care you have placed in choosing your ingredients is perfected and is where your creativity comes to life, supported by the technology of our cooking appliances: precise and intuitive to allow you to make the most of every raw material and recipe.

The Signature Kitchen Suite cooking range consists of handle-less combi ovens featuring a minimalist design, equipped with high-definition 7" LCD touch screens and set up for Wi-Fi connection. The two models available (Combi steam oven and Combi steam oven with microwave) can be paired and integrated with the warming drawer for a complete kitchen wall. Cooking has never been easier, even with the Flex induction hob, with its five combinable zones and quick controls that allow you to easily activate the most frequent cooking modes.



Cooking

Combi steam oven

An elegant, essential and handle-less design to enhance your kitchen's beauty and functionality.

The Combi steam oven pairs traditional and steam cooking to enhance the taste of the freshest ingredients, preserve their organoleptic properties and perfect your recipes.

True Benefits

Cooking with steam and hot air

The combination of hot air and steam allows you to prepare any type of dish, soft or crispy. The app and programmed recipes will help you find your ideal combination. Thanks to the descaling and residual water drainage function, you are sure to always use only fresh water. The evaporation function then perfectly dries any residual condensation in the oven.



100% steam, modulable and sous vide

The oven's integrated sous vide function allows you to preserve the vitamins, minerals and nutritional principles of each food, thus maintaining the best colour and fragrance. The oven can modulate steam intensity according as needed: 100% steam or steam assist which allows you to add three different steam intensities to hot air cooking.



Maximum hygiene with steam

The cleaning programs can be easily activated from the touch display of the oven. Two are available: Speed Clean sanitises in just 10 minutes while Steam Maintenance sterilises the oven chamber and prevents limescale formation. This enables to sanitise perfectly without adding chemical agents.



SMART TIP

SMART CONNECTION

The Combi steam oven oven is Wi-Fi ready and can be connected to the LG ThinQ app from which the functions can be managed remotely, including switch-on and activating the cooking programs. The app can also be used to download updates for the software and new pre-set recipes. Smart Diagnosis™ can also be used to check the correct functioning of the appliance from a mobile device.

Combi steam oven



Installation

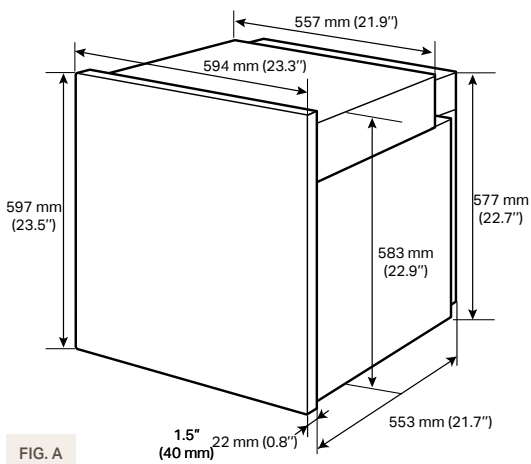

FIG. A

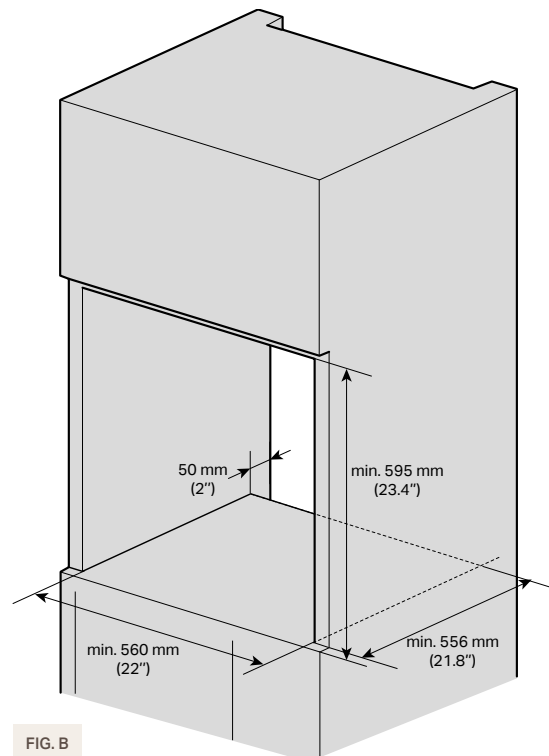

FIG. B

Installation in a high cabinet

There must be a gap of minimum 10 mm (0.4") between the rear of the installed oven and the connecting wall. Use the side holes of the oven (refer to arrow, Fig. A) for lifting. Kitchen cabinet in contact with the oven must be heat resistant up to 90 °C, and close units fronts up to at least 70 °C.

SKSOV2411S

General properties	EAN: 8806087744644
Interior coating	Blue porcelain enamel
Display	LCD TFT colour 7"
Wi-Fi enabled for SmartThinQ® control with iOS/Android app	●
Cook Mode	(18) Hot air, Eco Hot Air, Static, Fan Assisted, Pizza, Roasting, Light Roast, Rapid Heat Roast+, Small Grill, Large Grill, Proof, Keep Warm, Defrost, Warm Up, Bottom Heat, 100% Steam, Sous Vide, Steam-assist
"Gourmet Chef" automatic programs	20
Automatic opening handle-less door	●
Soft Open	●
Motion Sensor	●
Mood light (red)	●
External steam generation	●
Cooking with 100% steam with temperature regulation to C°	●
Sous-vide	●
Descaling	●
Drying	●
Water tank capacity	1 L
LED Interior Lighting	●
Speed clean	●
Door material	Opaque glass
Accessories included	2 telescopic guides, 1 wire grille, 1 deep pan, 1 baking tray, 1 perforated tray
Temperature probe	●
Energy label	
Energy efficiency class	A+
Cavity size	70 L
Energy consumption for conventional cycle (kW/h)	0.94
Energy consumption for fan assisted cycle (kW/h)	0.69
Power consumption kW	3.5
Technical Specifications	
Circuit breaker	20 A
Required power supply	230 V, 50 Hz
Plug type	F Type
Power supply type	Electrical
Net weight	57 kg

Silver Combi steam oven



Installation

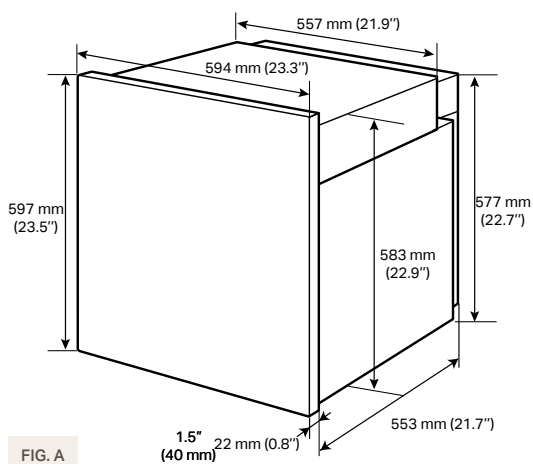

FIG. A

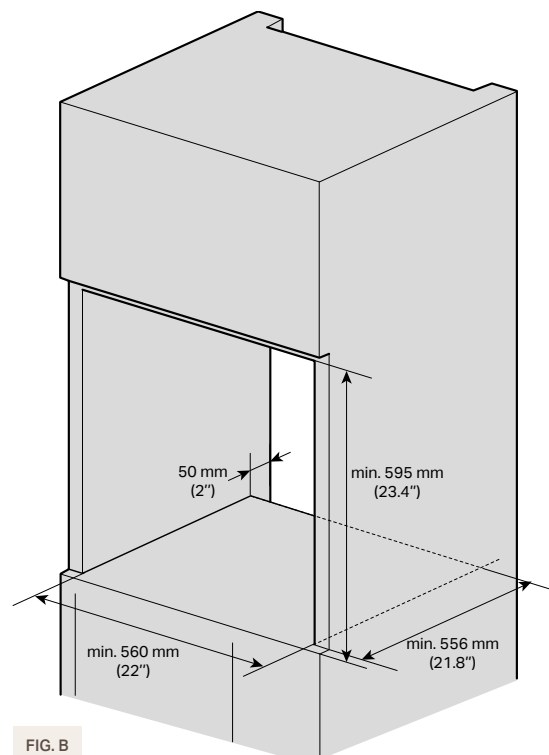

FIG. B

Installation in a high cabinet

There must be a gap of minimum 10 mm (0.4") between the rear of the installed oven and the connecting wall. Use the side holes of the oven (refer to arrow, Fig. A) for lifting. Kitchen cabinet in contact with the oven must be heat resistant up to 90 °C, and close units fronts up to at least 70 °C.

SKSOV2421MS

General properties	EAN: 8806084782519
Interior coating	Blue porcelain enamel
Display	LCD TFT colour 7"
Wi-Fi enabled for SmartThinQ® control with iOS/Android app	•
Cook Mode	(18) Hot air, Eco Hot Air, Static, Fan Assisted, Pizza, Roasting, Light Roast, Rapid Heat Roast+, Small Grill, Large Grill, Proof, Keep Warm, Defrost, Warm Up, Bottom Heat, 100% Steam, Sous Vide, Steam-assist
"Gourmet Chef" automatic programs	20
Automatic opening handle-less door	•
Soft Open	•
Mood light (red)	•
External steam generation	•
Cooking with 100% steam with temperature regulation to C°	•
Sous-vide	•
Descaling	•
Drying	•
Water tank capacity	1 L
LED Interior Lighting	•
Speed clean	•
Door material	Opaque glass
Accessories included	2 telescopic guides, 1 wire grille, 1 deep pan, 1 baking tray, 1 perforated tray
Temperature probe	•
Energy label	
Energy efficiency class	A+
Cavity size	70 L
Energy consumption for conventional cycle (kW/h)	0.94
Energy consumption for fan assisted cycle (kW/h)	0.69
Power consumption kW	3.5
Technical Specifications	
Circuit Breaker 20 A	20 A
Required power supply	230 V, 50 Hz
Plug type	F Type
Power supply type	Electrical
Net weight	57.9 kg



Cooking

Combi steam oven with microwave

An elegant, essential and handle-less design to enhance your kitchen's beauty and functionality.

This oven combines three cooking modes in a single product: traditional, microwave and steam assist.

True Benefits

Steam Combi Cooking

Traditional cooking, microwave and added steam. The oven is designed for those situations when, even in a small space, you want to be as creative as possible in the kitchen. The “combi steam” mode heats food gradually, using both the heat of the microwave and the moist heat of the steam. This function is suitable, for example, to heat up ready-made dishes which are quickly restored to their original consistency.



Microwave Function

The microwave features progressive power from 100W to 1000W, with 10 selectable levels, for extremely precise cooking. The pre-set recipes help to select the most suitable level. Furthermore, the Quick Start function enables to start the microwave mode with a single touch, with parameters that can be modified as needed.



Gourmet chef and custom recipes

All Signature Kitchen Suite oven models include the Gourmet Chef function which supports recipe preparation by indicating the most correct cooking steps starting from the raw material and its weight. The oven also enables to create and customise your own recipes and store them in your library.



SMART TIP

SMART CONNECTION

The combi steam oven with microwave is Wi-Fi ready and can be connected to the LG ThinQ app from which the functions can be managed remotely, including switch-on and activating the cooking programs. The app can also be used to download updates for the software and new pre-set recipes. Smart Diagnosis™ can also be used to check the correct functioning of the appliance from a mobile device.

Combi steam oven with microwave



Installation without a warming drawer

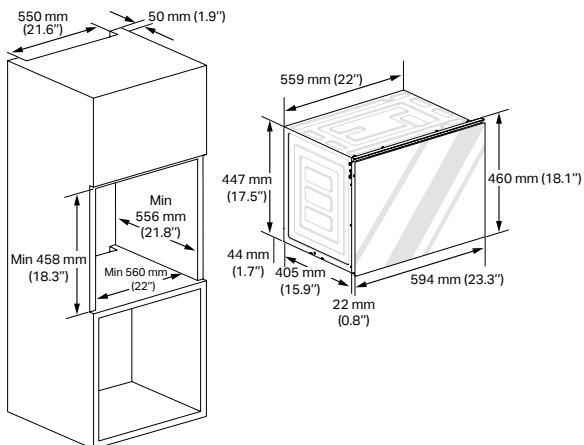

Installation in a high cabinet

There must be a gap of minimum 10 mm (0.4") between the rear of the installed oven and the connecting wall. Kitchen cabinet in contact with the oven must be heat resistant up to 90 °C, and close units fronts up to at least 70 °C.

Notes

Remove the back wall of the installation cabinet. If it is difficult to remove the back wall, make a hole at least 100 mm (3.94") in diameter.

Ventilation

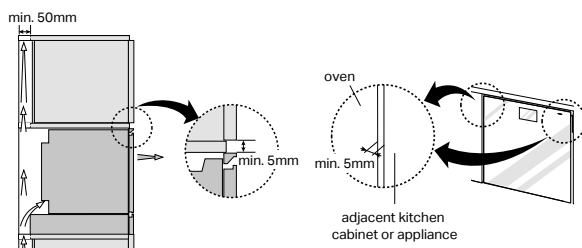

Notes

For correct ventilation, the ventilation opening of 50 mm (1.97") should be required between the back wall and the floor of the installation cabinet, the ventilation gap of 5 mm (0.197") is required between the oven top rim and the furniture lower rim, and between the oven both sides rim and the cabinet. These openings must not be closed in any way. Therefore ensure that the sides are not touching the front edges of the housing.

Connect the oven to the power supply.

SKSLV2401S

General properties	EAN: 8806098010455
Interior coating	Steel
Display	LCD TFT colour 7"
Wi-Fi enabled for SmartThinQ® control with iOS/Android app	●
Cook Mode	Microwave, Hot air, Static, Roasting, Auto Roast, Pizza, Grill, Crispy Grill, Defrost, Bottom Heat, Steam-assist
Microwave combi cooking mode	Hot Air, Roasting, Auto Roast, Grill, Steam assist
"Gourmet Chef" automatic programs	30
Automatic opening handle-less door	●
Soft Open	●
Motion Sensor	●
Mood light (red)	●
Microwave Inverter	●
Microwave cooking power	1000 W
External steam generation	●
Descaling	●
Drying	●
Water tank capacity	1 L
LED Interior Lighting	●
Speed clean	●
Door material	Opaque glass
Accessories included	Metal pan / Perforated pan / Rack
Technical Specifications	
Cavity size	32 l
Power consumption kW	3.15
Circuit Breaker 20 A	16 A
Required power supply	230 V, 50 Hz
Plug type	F Type
Power supply type	Electrical
Net weight	32 kg

Silver combi steam oven with microwave



Installation without a warming drawer

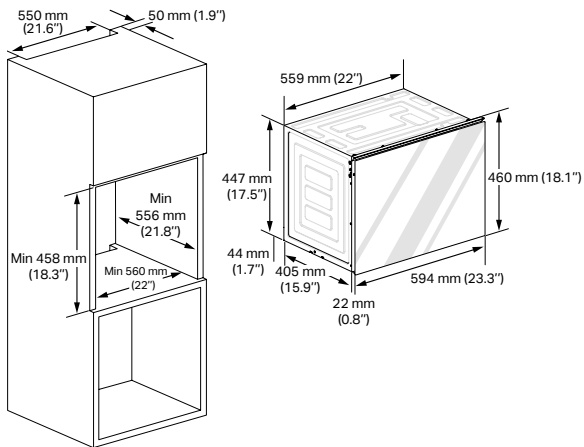

Installation in a high cabinet

There must be a gap of minimum 10 mm (0.4") between the rear of the installed oven and the connecting wall. Kitchen cabinet in contact with the oven must be heat resistant up to 90 °C, and close units fronts up to at least 70 °C.

Notes

Remove the back wall of the installation cabinet. If it is difficult to remove the back wall, make a hole at least 100 mm (3.94") in diameter.

Ventilation

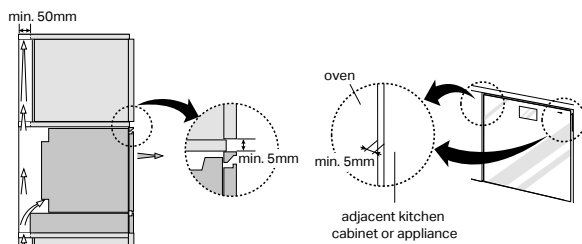

Notes

For correct ventilation, the ventilation opening of 50 mm (1.97") should be required between the back wall and the floor of the installation cabinet, the ventilation gap of 5 mm (1.97") is required between the oven top rim and the furniture lower rim, and between the oven both sides rim and the cabinet. These openings must not be closed in any way. Therefore ensure that the sides are not touching the front edges of the housing.

Connect the oven to the power supply.

SKSLV2421MS

General properties	EAN: 8806084782427
Interior coating	Steel
Display	LCD TFT colour 7"
Wi-Fi enabled for SmartThinQ® control with iOS/Android app	●
Cook Mode	Microwave, Hot air, Static, Roasting, Auto Roast, Pizza, Grill, Crispy Grill, Defrost, Bottom Heat, Steam-assist
Microwave combi cooking mode	Hot Air, Roasting, Auto Roast, Grill, Steam assist
"Gourmet Chef" automatic programs	30
Automatic opening handle-less door	●
Soft Open	●
Mood light (red)	●
Microwave Inverter	●
Microwave cooking power	1000 W
External steam generation	●
Descaling	●
Drying	●
Water tank capacity	1 L
LED Interior Lighting	●
Speed clean	●
Door material	Opaque glass
Accessories included	Metal pan / Perforated pan / Rack
Technical Specifications	
Cavity size	32 L
Power consumption kW	3.15
Circuit Breaker 20 A	16 A
Required power supply	230 V, 50 Hz
Plug type	F Type
Power supply type	Electrical
Net weight	32 kg



Cooking

Warming Drawer

Ideal addition to the combi steam oven with microwave.

The Warming drawer completes your kitchen wall with elegance.

WARMING DRAWER

True Benefits

Perfect combination

Thanks to its size, the Warming drawer perfectly pairs with the combi steam oven with microwave. Together they have a combined height of 60 cm equal to that of the combi steam oven, thus creating a perfect horizontal alignment.



4 warming settings

The Warming drawer can be set to 4 different operating settings: 1 (40°C) to let dough rise and heat cups and plates; 2 (55°C) to keep food warm; 3 (70°C) to warm up the dishes before serving them; 4 (80°C) to heat preparations taken out of the refrigerator.



Quality materials

Even the Warming drawer is built with resistant and quality materials, glass and stainless steel. Easy to clean, thanks to its flush installation and its aesthetics in line with the other ovens in the range, it is the perfect complement to create unique combinations in the kitchen.



Warming drawer



Installation of the compact oven with warming drawer

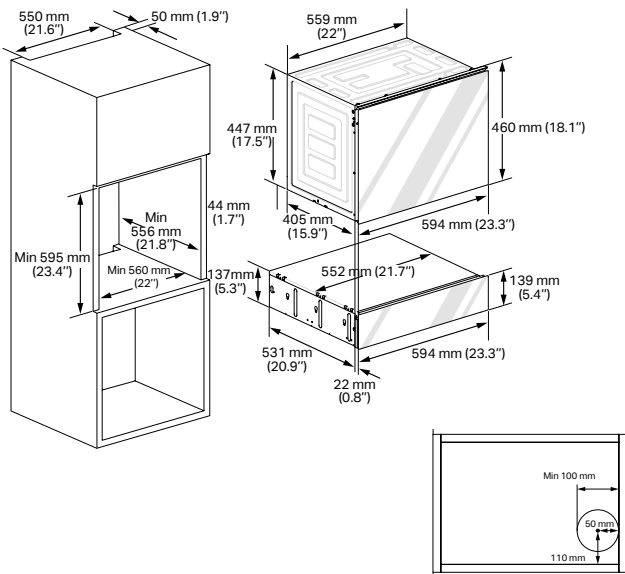

Installation in a high cabinet

There must be a gap of minimum 10 mm (0.4") between the rear of the installed oven and the connecting wall. Kitchen cabinet in contact with the oven must be heat resistant up to 90 °C, and close units fronts up to at least 70 °C.

Notes

Remove the back wall of the installation cabinet. If it is difficult to remove the back wall, make a hole at least 100 mm (3.94") in diameter that the drawer power cord can protrude on the back wall.

Ventilation

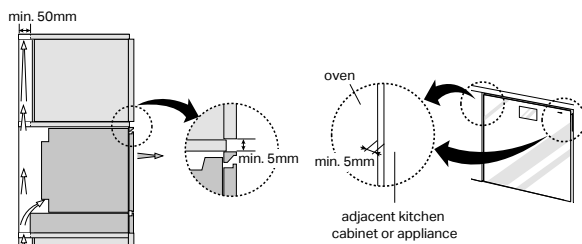

Notes

For correct ventilation, the ventilation opening of 50 mm (1.97") should be required between the back wall and the floor of the installation cabinet, the ventilation gap of 5 mm (1.97") is required between the oven top rim and the furniture lower rim, and between the oven both sides rim and the cabinet. These openings must not be closed in any way. Therefore ensure that the sides are not touching the front edges of the housing. Connect the oven to the power supply.

SKSWD2401S

General properties	EAN: 8806098008780
Finish	Black glass
Temperature levels	40°C - 55°C - 70°C - 80°C
Operating indicator	•
Pre-heat dishes	•
Keep warm	•
Proof	•
Defrost	•
Cooking at low temperature	•
Technical Specifications	
Cavity size	19 l
Power consumption kW	0.45
Circuit breaker	20 A
Required power supply	230 V, 50 Hz
Plug type	F Type
Power supply type	Electrical
Overall width	594 mm
Overall height	139 mm
Overall depth	531 mm

Warming drawer Silver



Installation of the compact oven with warming drawer

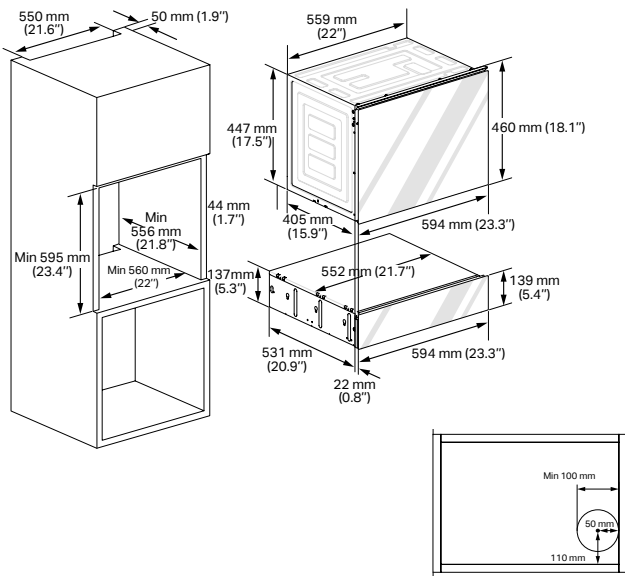

Installation in a high cabinet

There must be a gap of minimum 10 mm (0.4") between the rear of the installed oven and the connecting wall. Kitchen cabinet in contact with the oven must be heat resistant up to 90 °C, and close units fronts up to at least 70 °C.

Notes

Remove the back wall of the installation cabinet. If it is difficult to remove the back wall, make a hole at least 100 mm (3.94") in diameter that the drawer power cord can protrude on the back wall.

Ventilation

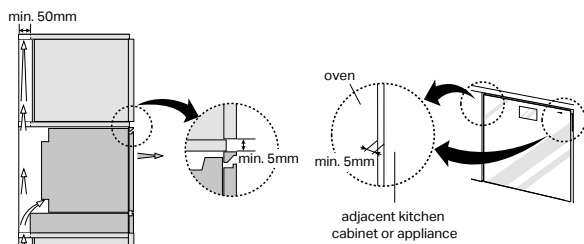

Notes

For correct ventilation, the ventilation opening of 50 mm (1.97") should be required between the back wall and the floor of the installation cabinet, the ventilation gap of 5 mm (1.97") is required between the oven top rim and the furniture lower rim, and between the oven both sides rim and the cabinet. These openings must not be closed in any way. Therefore ensure that the sides are not touching the front edges of the housing. Connect the oven to the power supply.

SKSWD2421MS

General properties	EAN: 8806084782526
Finish	Silver
Temperature levels	40°C - 55°C - 70°C - 80°C
Operating indicator	●
Pre-heat dishes	●
Keep warm	●
Proof	●
Defrost	●
Cooking at low temperature	●
Technical Specifications	
Cavity size	19 l
Power consumption kW	0.45
Circuit breaker	20 A
Required power supply	230 V, 50 Hz
Plug type	F Type
Power supply type	Electrical
Overall width	594 mm
Overall height	139 mm
Overall depth	531 mm



Cooking

Flex induction hob

The elegant and essential design enhances the beauty and functionality of your kitchen and work top.

The Flex induction hob consists of five cooking zones that can be extended according to the size of the pan.

True Benefits

17 power levels

From the central area of the touchscreen, it is possible to turn on the cooking zones by pressing directly on the image depicting the relevant area and selecting the number from the scale of numbers from 0 to 9, with increments of 0.5 for each level. From level 0.5 to keep warm without cooking, up to the Boost level to boil water, each level is associated with a type of food and cooking.

A table is provided in the user manual.



Cleaning lock

You can use this function when you want to clean the touch screen area of the hob, without the risk of activating cooking functions. To activate this setting, press the Cleaning Lock icon to lock the controls for 30 seconds. To unlock the controls, wait 30 seconds or press and hold the Cleaning Lock icon for 1 second.



Flexible cooking zones

The side Flex Zones can be used in Full Flex mode, thus extending the usable surface to the entire side.

The central Dual zone is highly performing and reaches 6800 W of power when set in boost mode.



SMART TIP

THREE PRE-SET PROGRAMS: C, F, T

S-Simmer, F - Melt, T - Boost (cooking quickly): pre-set programs to easily activate three of the most used cooking modes. It is therefore possible to access these easy settings without selecting a specific level.

Flex induction hob



Cutout dimensions - standard installation

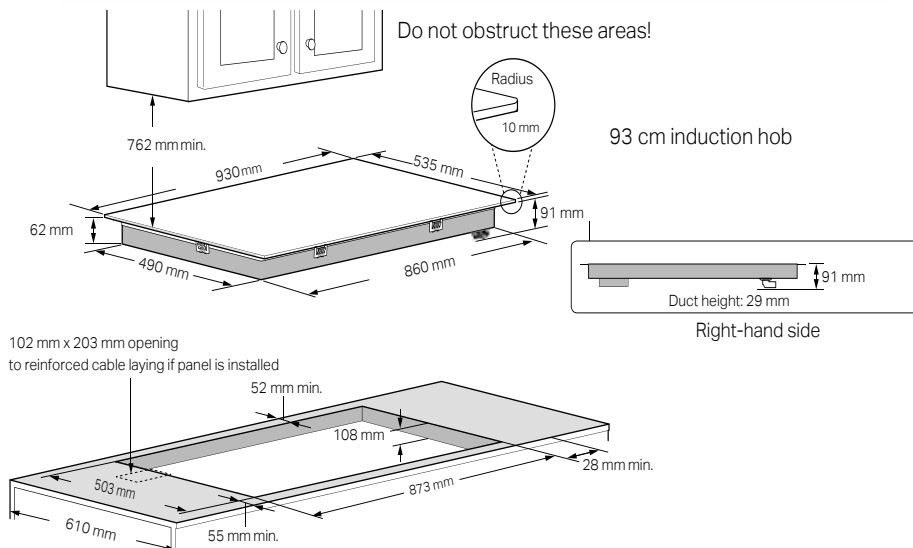

Cutout dimensions - flush installation

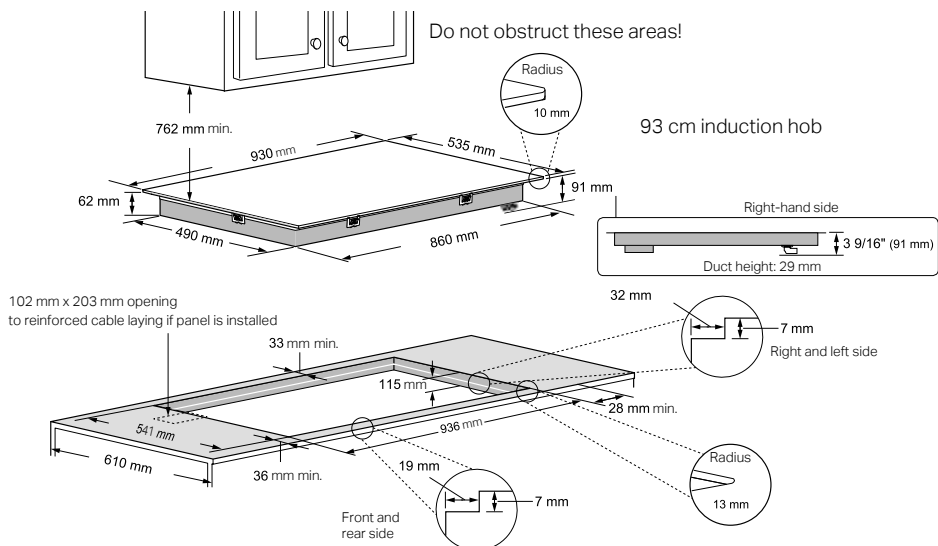

SKSIT3601G

Model	EAN: 8806098421350
Standard / flush	Standard / flush
Finish	Ceramic glass dark grey finish
General Properties	
Commands	7" TFT LCD Display
Logo print	Soft Printing under glass
Wi-Fi enabled for SmartThinQ® Control with iOS/Android App	●
Cooking indicator light (red)	●
Simmer	●
Melt	●
Boost	●
Number of power levels	17
Cleaning lock	●
Display brightness management	5 levels
Clock	●
Automatic detection of pots and pans	●
Timer	●
Cooking zones	
Power of the right & left front flex zone	1,700 W
Power of right & left front flex zone (Boost mode)	3,400 W
Power of right and left rear flex zone	1,700 W
Power of right & left rear flex zone (Boost mode)	3,400 W
Power of full right and left flex zone	3,300 W
Power of full right and left flex zone (Boost mode)	3,650 W
Power of dual centre zone	3,400 W
Power of dual centre zone (Boost mode)	6,800 W
Dimensions of front right flex zone	21.5 x 18.0 cm
Dimensions of front left flex zone	21.5 x 18.0 cm
Dimensions of rear right flex zone	21.5 x 18.0 cm
Dimensions of rear left flex zone	21.5 x 18.0 cm
Dimensions of full right and left flex zone	21.5 x 36.0 cm
Dimensions of dual centre zone	ø 28.0 cm
Energy Consumption	
Energy consumption of front left flex zone	171.3 Wh/kg
Energy consumption of front right flex zone	173.8 Wh/kg
Energy consumption of rear left flex zone	169.3 Wh/kg
Energy consumption of rear right flex zone	174.0 Wh/kg
Energy consumption of Dual zone Center	163.2 Wh/kg
Energy consumption of the hob calculated per kg	170.3 Wh/kg
Technical Specifications	
Hob type	Integrated hob
Heating technology	Induction cooking zones and cooking zones
Number of zones and/or cooking areas	5
Power consumption	10,200 W
Circuit breaker	50 A
Required power supply	230 V~, 50 Hz
Plug type	No Plug
Connection	1630 mm flexible 3-wire cable in the conduit
Energy	Electrical
Whole appliance size (H x W x D)	91 x 930 x 535 mm
Required cutout size (H x W x D)	146 x 873 x 503 mm
Minimum distance from front counter	55 mm (2.1")
Minimum distance from rear wall	52 mm (2")
Net weight	22.9 kg
Shipping Weight	26.6 kg
Consumption in Standby mode	0.5 W

Flex induction hob Silver



Cutout dimensions - standard installation

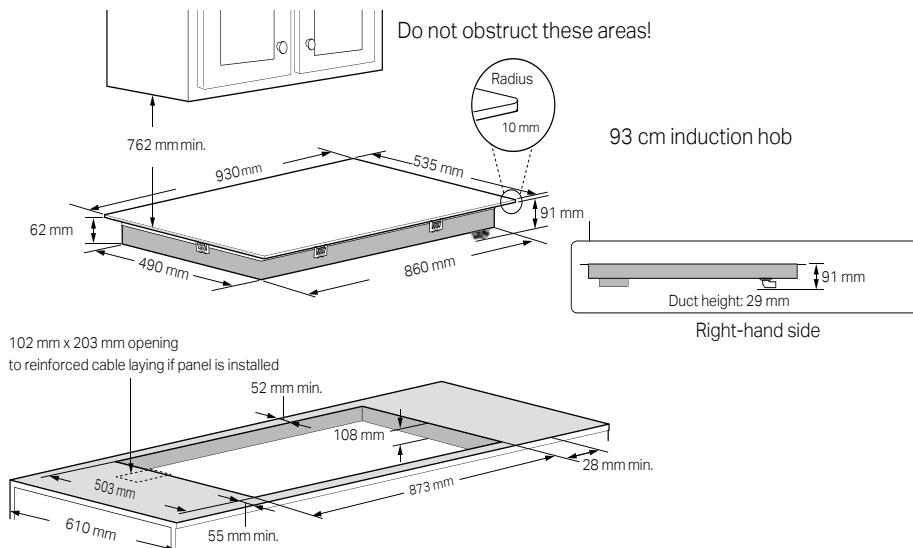

Cutout dimensions - flush installation

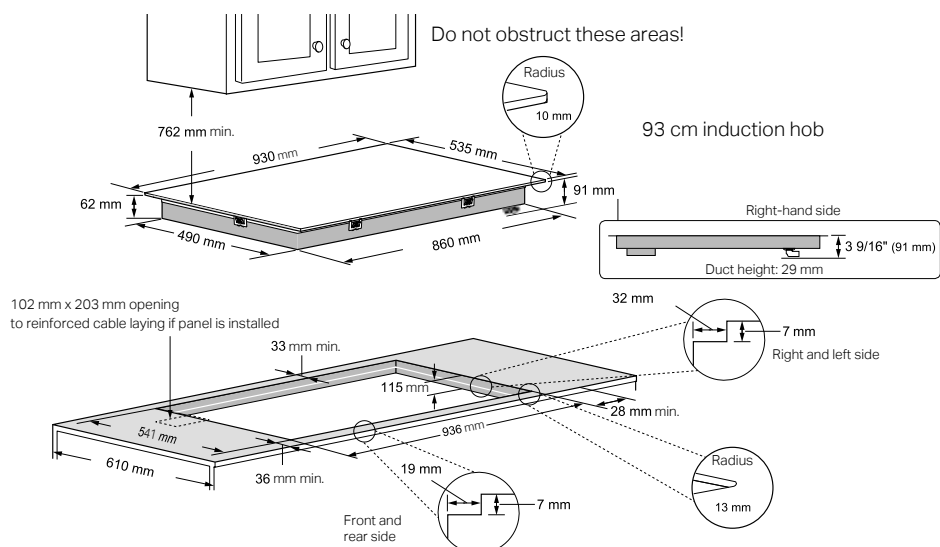

SKSIT3621MS

Model	EAN: 8806084782373
Standard / flush	Standard / flush
Finish	Metallic Silver
General Properties	
Commands	7" TFT LCD Display
Logo print	Soft Printing under glass
Wi-Fi enabled for SmartThinQ® Control with iOS/Android App	●
Cooking indicator light (red)	●
Simmer	●
Melt	●
Boost	●
Number of power levels	17
Cleaning lock	●
Display brightness management	5 levels
Clock	●
Automatic detection of pots and pans	●
Timer	●
Cooking zones	
Power of the right & left front flex zone	1,700 W
Power of right & left front flex zone (Boost mode)	3,400 W
Power of right and left rear flex zone	1,700 W
Power of right & left rear flex zone (Boost mode)	3,400 W
Power of full right and left flex zone	3,300 W
Power of full right and left flex zone (Boost mode)	3,650 W
Power of dual centre zone	3,400 W
Power of dual centre zone (Boost mode)	6,800 W
Dimensions of front right flex zone	21.5 x 18.0 cm
Dimensions of front left flex zone	21.5 x 18.0 cm
Dimensions of rear right flex zone	21.5 x 18.0 cm
Dimensions of rear left flex zone	21.5 x 18.0 cm
Dimensions of full right and left flex zone	21.5 x 36.0 cm
Dimensions of dual centre zone	ø 28.0 cm
Energy Consumption	
Energy consumption of front left flex zone	193.1 Wh/kg
Energy consumption of front right flex zone	193.1 Wh/kg
Energy consumption of rear left flex zone	193.1 Wh/kg
Energy consumption of rear right flex zone	193.1 Wh/kg
Energy consumption of Dual zone Center	197.8 Wh/kg
Energy consumption of the hob calculated per kg	194.0 Wh/kg
Technical Specifications	
Hob type	Integrated hob
Heating technology	Induction cooking zones and cooking zones
Number of zones and/or cooking areas	5
Power consumption	10,200 W
Circuit breaker	50 A
Required power supply	230 V~, 50 Hz
Plug type	No Plug
Connection	1630 mm flexible 3-wire cable in the conduit
Energy	Electrical
Whole appliance size (H x W x D)	91x930x535 mm (4"x36"x21")
Required cutout size (H x W x D)	146x873x503 mm (5.7"x34"x19")
Minimum distance from front counter	55 mm (2.1")
Minimum distance from rear wall	52 mm (2")
Net weight	22.9 kg
Shipping Weight	26.6 kg
Consumption in Standby mode	0.5 W



CONTROL PANEL

Normal Delicate Refresh Eco Turbo Washed Cook

1:57

EFFICIENCY

Dual Zone Half Load Energy Saver

PERFORMANCE

Steam High Temp Extra Dry Delay Start

STATUS

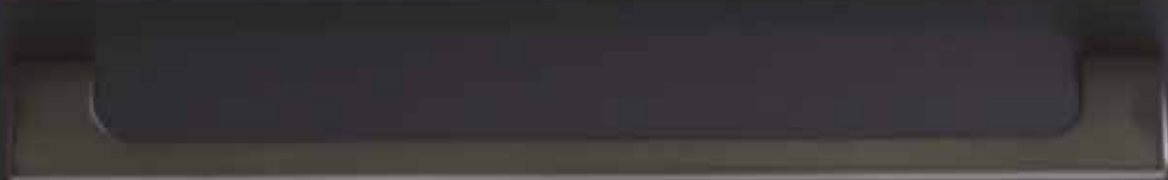



Washing

The Signature Kitchen Suite range of storage and cooking products is completed by an extremely highly performing dishwasher model, which utilises the natural power of steam to ensure the highest levels dish hygiene and protection.



Washing

Sliding hinge dishwasher

Equipped with PowerSteam technology, the dishwasher uses the natural power of steam, which can be activated on all programs, to achieve thorough cleaning without pre-rinsing.

The QuadWash™ rotating arms guarantee an even more thorough washing of the dishes thanks to multidirectional movements in four different directions.

True Benefits

PowerSteam Technology

Steam can be activated on all 10 washing programs, either automatically or with manual setting. Combined with water during the various steps, it guarantees impeccable cleaning and maximum shine of the dishes, whilst keeping the machine sanitised.



Rotating arms QuadWash™

The four rotating spray arms create water vortexes able to reach dishes at every point thanks to multidirectional oscillating movements, guaranteeing unparalleled cleaning. Once washing is complete, the door opens automatically, perfecting the drying stage.



Powerful and noiseless

Featuring a 10-year LG warranty, the latest generation Direct Drive motor is powerful and extremely noiseless, allowing you to use the dishwasher at any time of day. Furthermore, once washing is complete, the door opens automatically, facilitating the drying process.

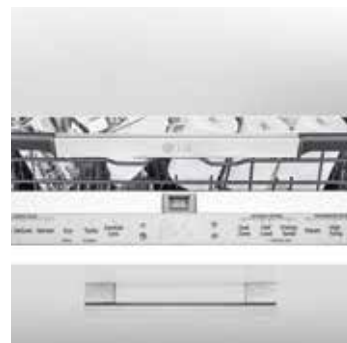

Flexible and customisable

With panel ready exteriors according to the kitchen finishes, the dishwasher can also be customised on the interiors, adapting to different load requirements. It is equipped with three baskets: an upper one for cutlery and two central ones for crockery, adjustable to three height levels. The Dual zone function makes it possible to activate two different washing powers (strong and delicate) in the two baskets within the same cycle.



SMART TIP

APPLIANCE CLEANING ALERT

Every 30 washes, an automatic warning light warns of the need to activate the dishwasher cleaning function to sanitise the machine by eliminating residues, odours and stains. This cycle is to be activated with an empty appliance.

SKSDW2402P

Sliding hinge dishwasher



Installation

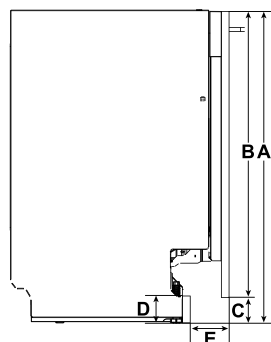
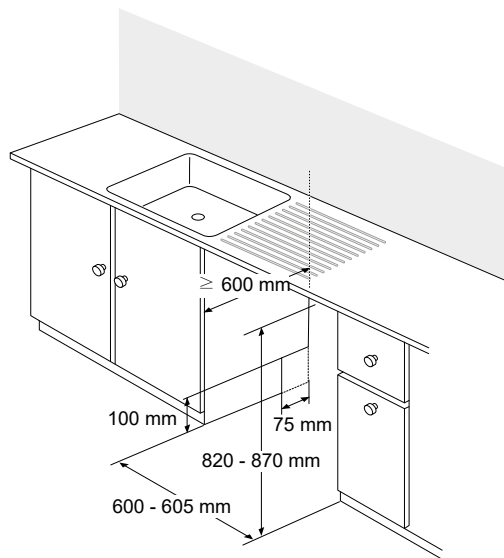

<Maximum size of 'B'>

A(mm) \ C(mm)	90	100	110	120	130	140	150	160
811	720	710	700	690	680	670	660	650
821	X	720	710	700	690	680	670	660
831	X	X	720	710	700	690	680	670
841	X	X	X	720	710	700	690	680
851	X	X	X	X	720	710	700	690
861	X	X	X	X	X	720	710	700

- D = C - 15mm
- E = 95 - 100mm

SKSDW2402P

General properties	EAN: 8806098608034
Covered	14
Inverter Direct Drive Motor	●
Wi-Fi enabled for SmartThinQ® control with iOS/Android app	●
TrueSteam™	●
QuadWash™	●
Programs	(10) Auto, Deep clean, Delicate, Refresh, Eco, Boost, Download cycle, Machine Clean, Rinse, Express
Options	(8) Dual zone, Half load, Energy saver, Steam, High temp, Extra Dry, Delayed Start, Control Lock
Drying Type Condensing / AOD	●
Drying type	Auto Open Condensation / Drying
Vario Plus washing system	●
3° height-adjustable basket	●
Auto opening door	●
Running time indicator	●
Salt refill indicator	●
Rinse refill indicator	●
Energy consumption and noise levels	
Energy efficiency class	D
Eco Program sound Level	43 dBA
Water consumption per cycle	9.5 L
Energy consumption per cycle	0.849 kWh
Standard cycle time (ECO)	193 min.
Express cycle time	56 min.
Boost cycle time	78 min.
Technical Specifications	
Required power supply	220 ~ 240V, 50Hz
Dimensions (WxDxH)	598x554x815 mm (23"x21"32")
Height of niche	815 ~ 875 mm (32" ~ 34")
Adjustable feet	60 mm (2")
Door panel technical specifications	
Width	590 mm - 594 mm (23.2" - 23.4")
Height	720 mm - 780 mm (28.3" - 30")
Thickness	16 mm - 22 mm (0,6" - 0,8")
Hinge capacity	2.5 kg - 11 kg









Showroom

We have designed a space focused on providing an experience, with displays that will surprise, inspire and tell a story.

Signature Kitchen Suite appliances take centre stage and tradition and innovation coexist in perfect harmony. This is a unique space to discover our products and experience the True to Food™ philosophy.





True to smart floor

Via the stairs, you reach a domestic environment, imagined as the home of a gallery manager, and a space that is more similar to a theatre set than an interior design project.

In the basement, Signature Kitchen Suite houses certain products from the other brands of the group, LG Signature and LG Objet, demonstrating LG's ability to provide smart cross solutions in all areas of the home.

A tribute to the city of Milan, the showroom has been designed by Studio Calvi Brambilla, placing pieces of furniture signed exclusively by great Milanese designers, including Achille Castiglioni, Franco Albini, Angelo Mangiarotti, Luigi Caccia Dominioni.

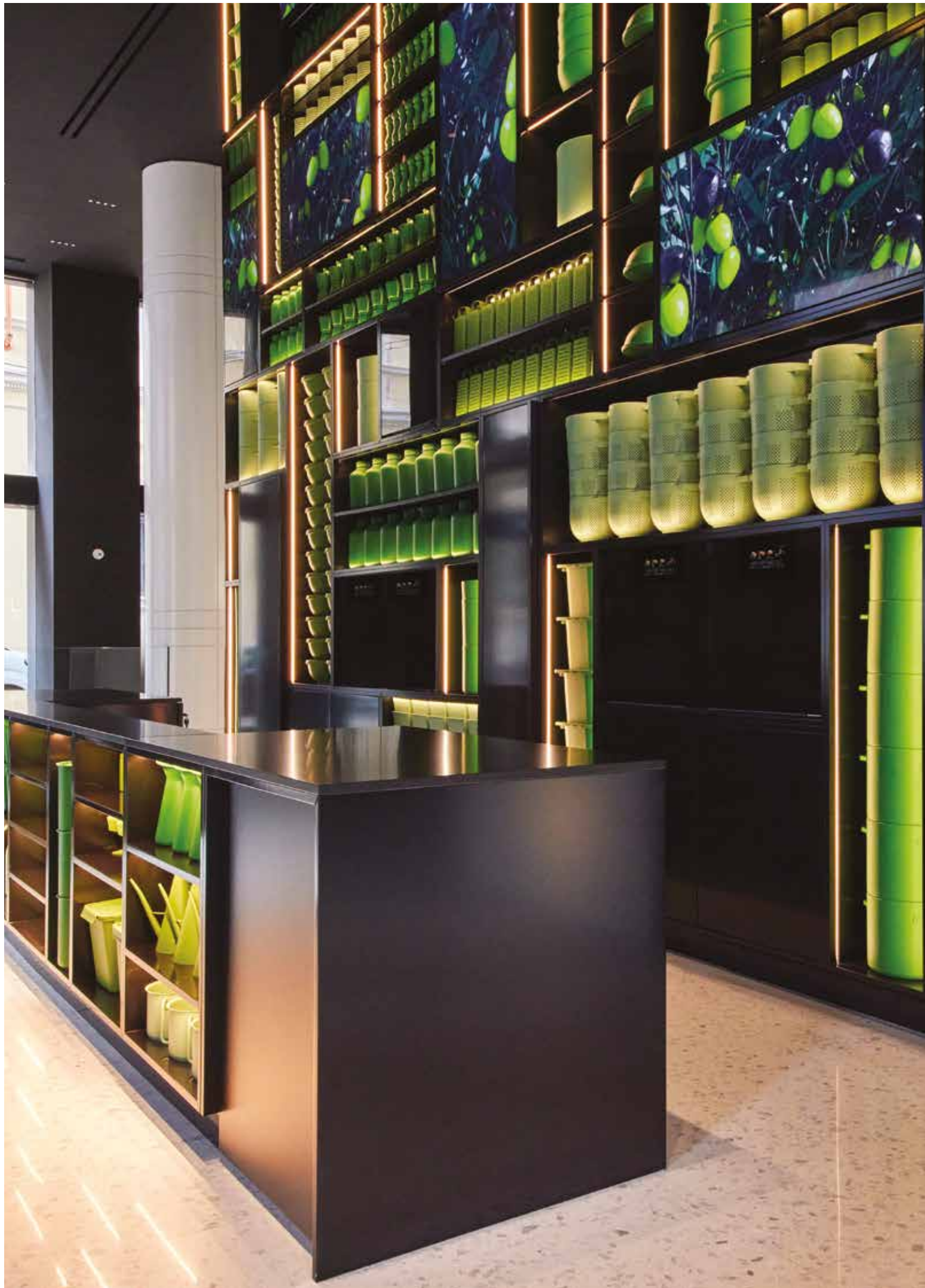



True to design floor

It is from the ground floor of the Signature Kitchen Suite showroom that the Calvi Brambilla architects illustrate how art, architecture and design find their space inside the brand's first European flagship store: an environment inspired by contemporary art galleries.

Tradition is visually represented by the pure pink lacquered metal elements that evoke the marble of the Milan Duomo paired with the terrazzo floor reminiscent of the Italian tradition.

At the entrance, the Accumulation Wall encloses design objects typical of the kitchen environment, LED screens and integrated appliances in a large wall, with the aim of summing up the brand philosophy and its three keywords: food, design, smart.

In the large area dedicated to showcooking activities, the appliances merge in harmony in a kitchen with white flute glass and pink steel profiles with an eye to the True to food concept reminiscent of the typical elegant glass.





True to food™ floor

The showroom transforms into a hub to communicate and share the True to food™ philosophy.

The first floor, dedicated to the Food academy, exalts the Signature Kitchen Suite manifesto focusing on the true essence of food to maintain quality from farm to table, making it the absolute protagonist.

True to food™ is sincerity, it is authenticity, it is an approach aimed at rediscovering the value of food: the six active stations become the location to experience our mantra through tastings and cooking classes.



Showroom

Food academy

A world of True to Food™ experiences awaits you at our Food academy.

A dedicated space for cooking passion where you can experiment with the use of our appliances, with six equipped workstations in addition to that of the chef.

Courses & Experience

Cooking Classes

Thematic cooking lessons with seasonal menus, with attention to ingredient selection and variety and the most suitable cooking and storage techniques.



Cocktail Experience

On this voyage through the secrets of mixology and the culture of spirits, you will discover their wildly different histories, origins, and uses, finishing off by mixing the perfect cocktail.



Wine Experience

Tasting itineraries to discover labels selected from top of the class producers, accompanied by historical anecdotes, curiosities and advice so as to make an informed choice.





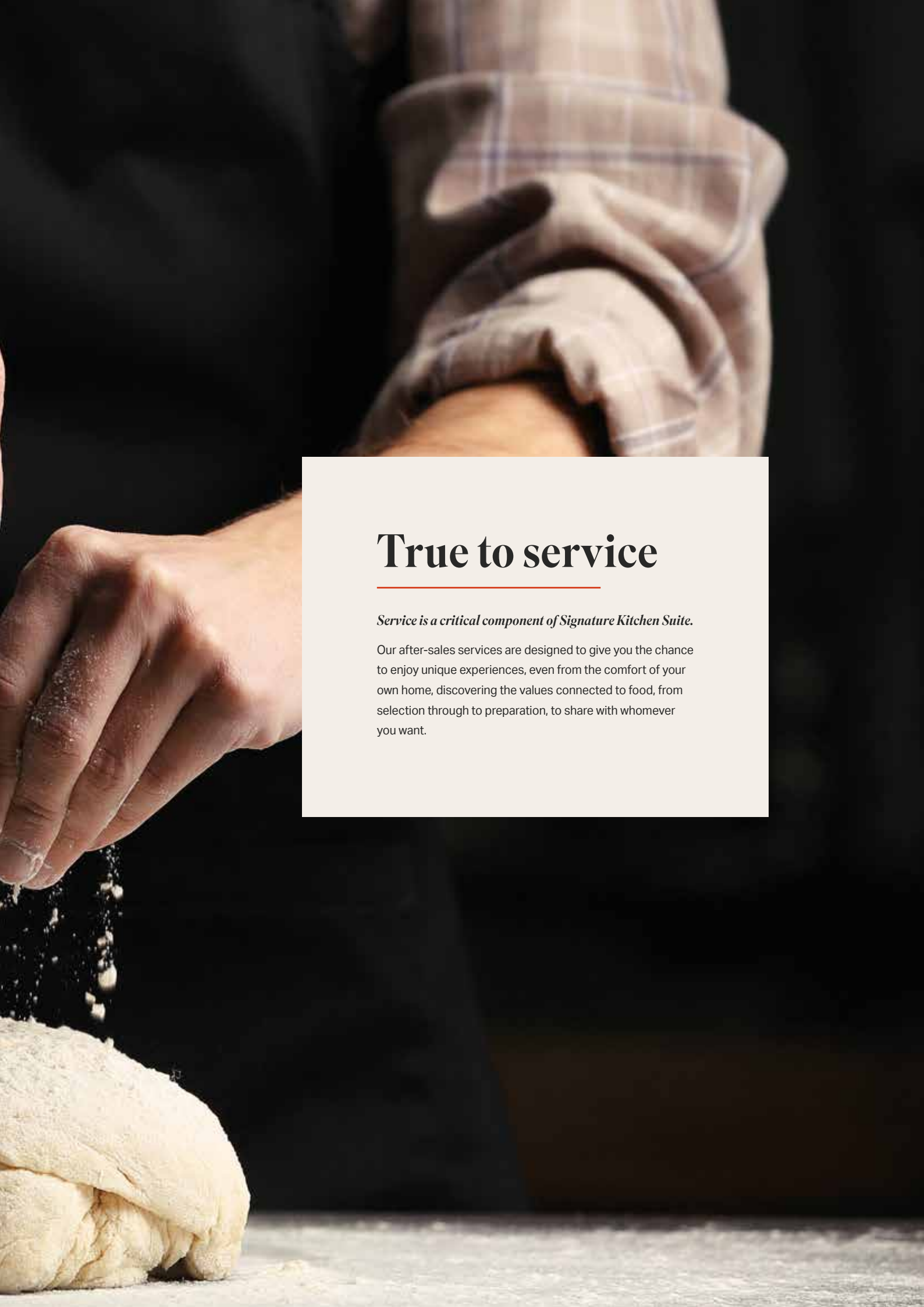

True to service

Service is a critical component of Signature Kitchen Suite.

Our after-sales services are designed to give you the chance to enjoy unique experiences, even from the comfort of your own home, discovering the values connected to food, from selection through to preparation, to share with whomever you want.

TRUE TO SERVICE

Services

Warranty

All Signature Kitchen Suite appliances are covered by a 2-year warranty. An additional third year is offered by Signature Kitchen Suite in order to provide its customers with greater peace of mind when choosing our appliances.

Smart Check

Signature Kitchen Suite supports you to properly operate and maintain your appliances.

Service

We guarantee the priority response from one of our specialised technicians, who will intervene with the utmost promptness, meeting your needs and urgencies, during the weekdays.

Tutorials

Do you need some help understanding how your appliances work? Contact us for personalised advice by phone or directly in your home.

Experiences

Personal Food Shopper

A chef will go shopping with you and help you identify and select the food that best suits your tastes and recipes.

@Home Masterclass

A private lesson at home in your kitchen. Choose the theme and get ready to welcome a Signature Kitchen Suite chef for an exclusive experience.

Full Wine Cellar and sommelier

A sommelier will help you fill your new Signature Kitchen Suite Wine cellar according to your budget with the wines most suitable for your tastes, illustrating their characteristics and setting the correct storage and serving temperatures.

Receive your box with selected true to food

Voucher for a calendar course at the Food Academy where you can learn new techniques and recipes and become familiar with the Signature Kitchen Suite products.

Experiences

Model	Description	Personal Food Shopper	Full Wine Cellar and Sommelier	Masterclass @home	Free evening course
SKSFD3614P	French Door 36"	•		•	•
SKSCR3011P	Refrigerator 30"	•			•
SKSCR2411P	Refrigerator 24"	•			•
SKSCF2411P	Freezer 24"	•			•
SKSCF1811P	Freezer 18"	•			•
SKSUD2402P	Undercounter convertible refrigerator	•			•
SKSCW242RP	Wine cellar 24"		•		•
SKSCW182RP	Wine cellar 18"		•		•
SKSUW2401G	Undercounter wine cellar		•		•
SKSOV2411S	Combi steam oven			•	•
SKSOV2421MS	Combi steam oven Silver			•	•
SKSLV2401S	Combi steam oven with microwave			•	•
SKSLV2421MS	Silver combi steam oven with microwave			•	•
SKSWD2401S*	Warming drawer			•	•
SKSWD2421MS*	Warming drawer Silver			•	•
SKSIT3601G	Flex induction hob				•
SKSIT3621MS	Flex induction hob Silver				•
SKSDW2402P	Sliding hinge dishwasher				•

* The warming drawer is intended as linked to 1 other product for the provision of services





Contact details

Signature Kitchen Suite Customer Service is here to help, offering you specific advice on choosing the best appliances for your needs.

Visit the showroom or contact us to make an appointment or for more information on Signature Kitchen Suite products and services.

SHOWROOM

Via A. Manzoni, 47 - 20121 Milano
+39 02 5002 0793 | showroom@signaturekitchensuite.it

DISTRIBUTØR | SCANDINAVIA

Siljander AS
Salhusvingen 27
5107 Salhus
Norway
Tlf +47 55 53 44 00
post@siljander.no
www.siljander.no





www.signaturekitchensuite.it



© 2023 Signature Kitchen Suite. All rights reserved.

Design, features and specifications are subject to change without notice.

The specifications are for planning purposes only.

Images are only representative of the product. Please refer to the product installation instructions for final dimensional data and other details before making customised recesses or panels.